

012



Dean C. Logan
Los Angeles County
Registrar-Recorder/County Clerk

Official Sample Ballot
City of West Hollywood
General Municipal Election
March 5, 2019

Polls open at 7 am and close at 8 pm

lavote.net



Voting instructions

How to vote at your polling place on Election Day

1

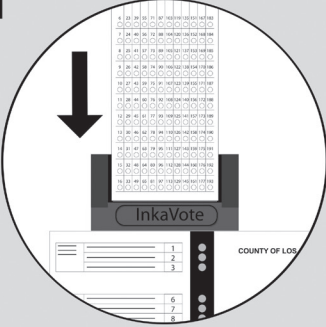

2

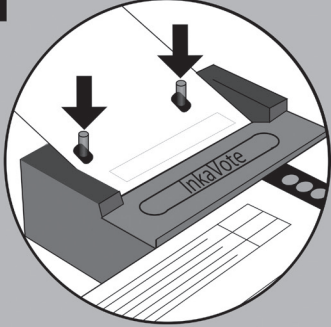

3

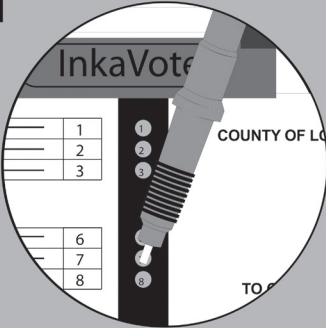

4

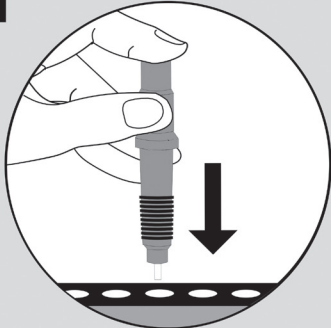

5

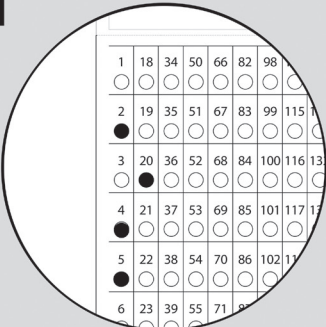

6

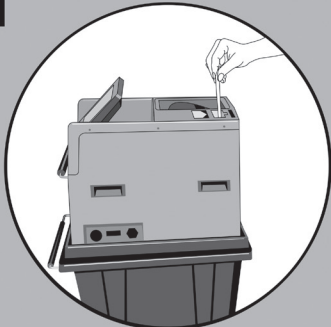



Voting for write-in candidates

How to vote for a person not listed on the ballot

Write the name and office of the official write-in candidate in the “write-in” portion of the ballot. A list of “Qualified Write-in Candidates” is available 11 days before the election at lavote.net. See a pollworker for a list of qualified candidates.

You may not write-in a candidate and vote for a candidate on the ballot for the same office.

At the polling place

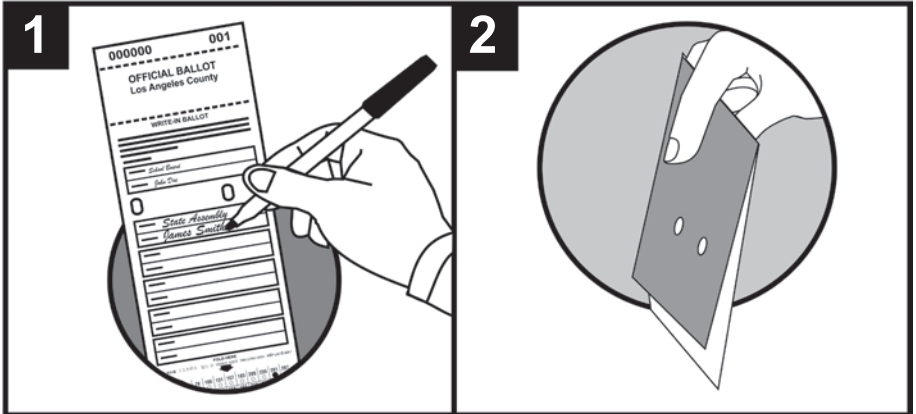

By mail

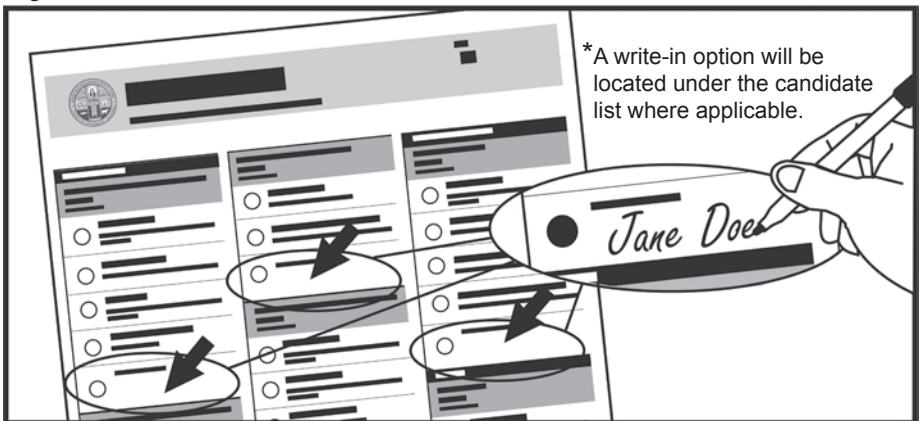



Information for voters

Offices on the ballot

March 5, 2019 marks the date for the General Law and Charter City Elections. This ballot will include contests for local offices and measures. Review your Sample Ballot and Visit lavote.net to ensure you are ready for Election Day!

Do you need assistance voting?

If a voter declares under oath that they are unable to mark a ballot the voter may receive assistance marking their ballot by two (2) persons of their selection (E.C. § 14282).



Vote By Mail drop-off locations

Vote By Mail ballot drop-off locations

The Registrar-Recorder/County Clerk is providing Vote By Mail drop-off locations for the March 5, 2019 General Law and Charter City Elections.

Beginning February 5th, any voter may drop off their voted ballot at one of many convenient locations throughout Los Angeles County.

Before you return your VBM ballot make sure:

- 1) Your ballot is securely placed inside the Vote by Mail envelope.
- 2) You sign the back of the Vote by Mail envelope.

For details on the program and a listing of ballot drop-off locations, please visit lavote.net.



New Vote by Mail (VBM) materials

Los Angeles County has redesigned your Vote by mail (VBM) materials making it easier and more convenient to vote by mail.

What's new?

New ballot cards and envelope

- Larger, full face ballot
- Easier to read
- Easier to fill out
- Easier to understand
- No postage necessary

Multilingual ballots

We offer ballots in 12 languages.

Call our office to request your multilingual ballot at **(800) 815-2666, option 3**

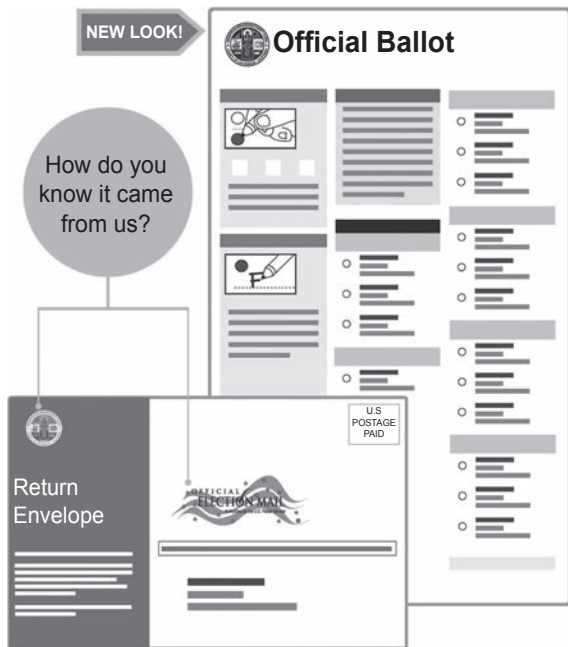

Return options

You can easily return your VBM ballot via USPS. **No postage is required.** In addition, you can drop it off at any voting location on Election Day or one of our conveniently located ballot drop-off locations.

Visit LAvote.net to request a VBM ballot, find a VBM ballot drop-off location or to track your VBM ballot.



Apply to vote by mail

One-time Vote By Mail

You can request a ballot by mail starting 29 days before the election. Apply by doing one of the following:

- Visit **lavote.net** and submit your request online.
- Tear off and mail back the application on the back cover page of this booklet.
- Send a letter signed by the voter that includes the voter's residence address and where to send the Vote By Mail ballot:
Registrar-Recorder/County Clerk
P.O. Box 30450, Los Angeles, CA 90030-0450.
- Apply by calling (800) 815-2666, option 2.

Permanent Vote By Mail

California law allows a voter to declare that they want to automatically vote by mail every election. You can request a ballot mailed to you automatically every time there is an election. This is called Permanent Vote By Mail status.

You can download an application at **lavote.net** or just check the box on the Vote By Mail application on the back cover of this booklet.

The image shows a portion of the 'Application to Vote By Mail' form. At the top left, there is a header 'Application to Vote By Mail' with a checkmark icon. Below this are several horizontal lines for text entry. A large 'X' is marked on one of the lines. To the right, a callout bubble points to a checkbox that is checked, with the text: 'I want to be a permanent Vote By Mail voter. You will automatically receive a ballot and vote by mail every election.' Below the form, there is a '000' label and a wheelchair accessibility icon. At the bottom center, there is a logo for 'OFFICIAL ELECTION MAIL' with the text 'Authorized by the U.S. Postal Service' underneath. A second, larger callout bubble at the bottom of the page repeats the same text as the first callout.



Voter Bill of Rights

You have the following rights:

- 1. The right to vote if you are a registered voter.** You are eligible to vote if you are:
 - a U.S. citizen living in California
 - not currently in state or federal prison or on parole for the conviction of a felony
 - at least 18 years old
 - not currently found mentally incompetent to vote by a court
 - registered where you currently live
- 2. The right to vote if you are a registered voter even if your name is not on the list.**

You will vote using a provisional ballot. Your vote will be counted if elections officials determine that you are eligible to vote.
- 3. The right to vote if you are still in line when the polls close.**
- 4. The right to cast a secret ballot** without anyone bothering you or telling you how to vote.
- 5. The right to get a new ballot if you have made a mistake**, if you have not already cast your ballot. You can:
 - Ask an elections official at a polling place** for a new ballot,
 - Exchange your vote-by-mail ballot** for a new one at an elections office, or at your polling place, or
 - Vote using a provisional ballot.**
- 6. The right to get help casting your ballot** from anyone you choose, except from your employer or union representative.
- 7. The right to drop off your completed vote-by-mail ballot at any polling place** in California.
- 8. The right to get election materials in a language other than English** if enough people in your voting precinct speak that language.
- 9. The right to ask questions to elections officials about election procedures** and watch the election process. If the person you ask cannot answer your questions, they must send you to the right person for an answer. If you are disruptive, they can stop answering you.
- 10. The right to report any illegal or fraudulent election activity** to an elections official or the Secretary of State's office.

If you believe you have been denied any of these rights, call the Secretary of State's confidential toll-free Voter Hotline at (800) 345-VOTE (8683).

 On the web at www.sos.ca.gov

 By phone at (800) 345-VOTE (8683)

 By email at elections@sos.ca.gov



Translated election material

1-800-815-2666 option 3

- **Call to receive translated election materials, polling place information or assistance with LAvote.net.**
- Позвоните, чтобы получить переведенные материалы о выборах, информацию о месте голосования или помощь LAvote.net.
- Llame para recibir materiales electorales traducidos, información sobre lugares de votación o asistencia con LAvote.net.

The Federal Voting Rights Act requires voter information, including a sample ballot booklet be available in English as well as Russian and Spanish.



Voting Solutions for All People Vote Center Placement Project

In 2020, Los Angeles County will transition from polling places to Vote Centers. To ensure these locations are accessible to voters, the County has partnered with experts to conduct the Vote Center Placement Project.

What we're doing

LA County will conduct a comprehensive spatial analysis to understand when voters are most likely to vote.



Accessibility



Security



Proximity



Convenience



Availability

How we get there

To ensure that community needs are addressed, the County will:

- Work directly with citizen advisory groups
- Hold stakeholder meetings
- Conduct community surveys
- Provide an interactive online platform to collect community input

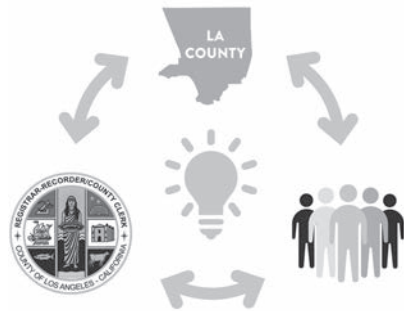

What voters get

- A new voting experience
- Convenient, secure and accessible Vote Centers available 11 days
- Vote by Mail Drop-Off Locations available for 29 days
- Mobile and Pop-up Vote Centers
- Flexibility to vote at any location in County



For more information, visit [VSAP.lavote.net](https://www.vsap.lavote.net)

CITY

WEST HOLLYWOOD CITY GENERAL MUNICIPAL ELECTION

Member of the City Council Vote for no more than Three	LINDSEY P. HORVATH West Hollywood Councilmember	2 ➔ <input type="radio"/>
	BRENDAN HOOD Marketing Analytics Director	3 ➔ <input type="radio"/>
	JAMES DUKE MASON Public Relations Specialist	4 ➔ <input type="radio"/>
	SHAWN DAVIS MOONEY Senior Living Executive	5 ➔ <input type="radio"/>
	LAUREN MEISTER West Hollywood Councilmember	6 ➔ <input type="radio"/>
	JACK CLINE Registered Nurse	7 ➔ <input type="radio"/>
	MARQUITA THOMAS Non-Profit Executive Director	8 ➔ <input type="radio"/>
	JOHN D'AMICO West Hollywood City Councilmember	9 ➔ <input type="radio"/>
	TOM DEMILLE Artist	10 ➔ <input type="radio"/>
	SEPI SHYNE Attorney	11 ➔ <input type="radio"/>
	ERIC JON SCHMIDT Retired Fitness Trainer	12 ➔ <input type="radio"/>

WEST HOLLYWOOD CITY MEASURE Y

Y	Shall an ordinance be adopted establishing a Cannabis Business Tax on gross receipts from the sale of adult-use cannabis and adult-use cannabis products, at a rate of 7.5%, estimated to raise \$5,500,000 annually to be used locally to fund general municipal services in West Hollywood such as public safety, street repair, homeless services, pedestrian/bike safety, and parks, until ended by voters and subject to annual public review of spending and independent financial audits?	14	YES ➔ <input type="radio"/>
		15	NO ➔ <input type="radio"/>

WEST HOLLYWOOD CITY MEASURE B

B	Shall Resolution No. 18-5104 be adopted, approving a General Plan Amendment for the Arts Club Project at 8920 Sunset Boulevard, thereby allowing the project to proceed?	18	YES ➔ <input type="radio"/>
		19	NO ➔ <input type="radio"/>

PLEASE NOTE: The order in which candidates' names appear on the ballot is determined by a random drawing of 26 letters of the alphabet.

END OF BALLOT



Candidate statements & measures

The following pages may contain Candidate Statements, and/or Ballot Measure Analyses, Arguments or Rebuttals.

Candidates for local offices have the option of including a statement, for which they pay a fee, unless the governing body pays the fee.

In compliance with the law, only English and Spanish language Candidate Statements are included in this booklet. Each candidate that submitted a Spanish language Candidate Statement has paid an additional fee.

Candidate Statements, Arguments or Rebuttals In Favor, or/and Against Ballot Measures are not edited or verified for accuracy by any elections officials.

Arguments and/or Rebuttals are the opinions of the authors.

STATEMENT OF JACK CLINE
CANDIDATE FOR MEMBER OF THE CITY COUNCIL
WEST HOLLYWOOD CITY GENERAL MUNICIPAL ELECTION

Occupation: Registered Nurse

My Name is Jack Cline. I am 49 years old. I am a Registered Nurse and Nurse Practitioner. I hold a Master's Degree from Ball State University. I have been a Nurse for more than 25 years. I will bring the same values I have as a Nurse to my City Council Position which are based upon caring and compassionate advocacy for others. Public Safety and the wellbeing of Residents are top priorities for me. I am also a proud member of the California Nurses Association. I am a Contract Negotiator with ten years of experience negotiating for better Patient Care. Save One life You're A Hero. Save 100 Lives, You're A Nurse.

DECLARACIÓN DE JACK CLINE
CANDIDATO PARA MIEMBRO DEL CONCEJO MUNICIPAL
ELECCIÓN MUNICIPAL GENERAL DE LA CIUDAD DE
WEST HOLLYWOOD

Ocupación: Enfermero Registrado

Mi nombre es Jack Cline. Tengo 49 años. Soy Enfermero Registrado y Profesional de Enfermería. Tengo una Maestría de la Universidad Ball State. He sido Enfermero por más de 25 años. Llevaré los mismos valores que tengo como Enfermero, que están basados en el cuidado y defensa compasiva para otros, a mi Posición en el Concejo Municipal. La Seguridad Pública y el bienestar de los Residentes son las principales prioridades para mí. Soy también un miembro orgulloso de la Asociación de Enfermeros de California. Soy un Negociador de Contratos con diez años de experiencia negociando un mejor Cuidado de Pacientes. Salve Una vida y Usted es Un Héroe. Salve 100 Vidas, Usted es Un Enfermero.

STATEMENT OF JOHN D'AMICO
CANDIDATE FOR MEMBER OF THE CITY COUNCIL
WEST HOLLYWOOD CITY GENERAL MUNICIPAL ELECTION

More living. On our terms.

Every day I work to ensure that West Hollywood continues to be a safe, affordable place to live, work and play. The values that make West Hollywood unique include a commitment to housing that is livable and attainable, social services that help people live their authentic lives to the fullest, a focus on public safety, civil rights, the importance of every point of view, and a creative spirit that keeps our city humane, sustainable, essential and growing.

With your help, we can expand the best parts of West Hollywood and work on the pieces that are unfinished. Since first being elected, I have helped bring about great progress in important ways:

- West Hollywood has doubled the number of affordable housing units, exceeding State and local goals and continuing to include required on-site units for all income levels,
- Strengthened our rent-control laws, ensuring that residents are safe in their rent-controlled units.
- Expanded public safety and policing programs, improving traffic safety on Fountain Avenue and reducing excess traffic in our residential neighborhoods.
- Worked on smart fixed-rail transit options and improving and extending our bike lanes. The Cityline, Pick-up Line and Sunset Trip are big successes.
- Advocated for more funding for human services that improve the lives of seniors every day. Our homeless initiatives are the best in the County, linking people to care, resources and permanent housing. I support our LGBT community services and Planned Parenthood to make sure people of all ages have access to essential care.
- Championed small business initiatives to bring new interest in our neighborhood business storefronts.
- Brought sustainability policies to create the healthiest buildings in the region, reducing impacts on our air, water, and neighborhoods. Resiliency and a new commitment to smart growth for development has created award-winning buildings and urban plans that put our community and environment first.

(Continued on next page)

STATEMENT OF JOHN D'AMICO (Continued)

- And the two new dog parks have been a tremendous success.

In all these ways and more, I communicate our community's core values and plan for the future that we want to see.

And now, I am asking for your vote again.

You have trusted me with West Hollywood. Please continue to send me your ideas about how we can invent the City of West Hollywood we all want.

Contact me at ourweho@me.com or text / call my cell at 310.498.5783.
www.ourweho.com

This is our city. More living. On our terms.

DECLARACIÓN DE JOHN D'AMICO
CANDIDATO PARA MIEMBRO DEL CONCEJO MUNICIPAL
ELECCIÓN MUNICIPAL GENERAL DE LA CIUDAD DE
WEST HOLLYWOOD

Sigamos viviendo. Bajo nuestras condiciones.

Todos los días trabajo para garantizar que West Hollywood continúe siendo un lugar seguro y asequible para vivir, trabajar y jugar. Los valores que hacen que West Hollywood sea único incluyen un compromiso con viviendas habitables y alcanzables, servicios que ayuden a que las personas vivan plenamente sus vidas auténticas, un enfoque en la seguridad pública, derechos civiles, la importancia de tener en cuenta todos los puntos de vista y un espíritu creativo que mantenga nuestra ciudad humana, sostenible, esencial y en desarrollo.

Con su ayuda, podemos ampliar las mejores partes de West Hollywood y trabajar en las obras que están sin terminar. Desde la primera vez que me eligieron, he ayudado a contribuir con un gran progreso en diversos aspectos importantes:

- West Hollywood ha duplicado la cantidad de unidades de viviendas asequibles, superando los objetivos Estatales y locales y seguir incluyendo unidades en obra necesarias para todos los niveles de ingresos,
- Ha fortalecido nuestras leyes de control del alquiler, garantizando la seguridad de los residentes en sus unidades de alquiler controlado.
- Ha expandido los programas de seguridad pública y vigilancia policial, mejorando la seguridad vial en Fountain Avenue y reduciendo el exceso de tráfico en nuestros vecindarios residenciales.
- Ha trabajado en opciones inteligentes de transporte ferroviario y mejorando y extendiendo nuestras aceras. Cityline, Pick-up Line y Sunset Trip representan grandes éxitos.
- Ha abogado por más fondos para los servicios humanos que todos los días mejoran las vidas de las personas mayores. Nuestras iniciativas para los indigentes son las mejores del Condado, ya que conectan a las personas con el cuidado, los recursos y las viviendas permanentes. Nuestros servicios comunitarios de LGBT (Lesbianas, Homosexuales, Bisexuales y Transexuales) y Planned Parenthood (Planificación Familiar) cuentan con mi apoyo para garantizar que las personas de todas las edades tengan acceso al cuidado esencial.
- Ha defendido iniciativas de pequeñas empresas para aportar nuevos intereses en nuestros escaparates comerciales del vecindario.
- Ha formulado políticas de sustentabilidad para crear los edificios más saludables de la región, y reducir los impactos en nuestro aire, agua y vecindarios. La resiliencia y un nuevo compromiso con un crecimiento inteligente del desarrollo han provocado la creación de edificios ganadores

(Continúa en la página siguiente)

DECLARACIÓN DE JOHN D'AMICO (Continuación)

de premios y planes urbanos que ponen a nuestra comunidad y medio ambiente en primer lugar.

- Y los dos nuevos parques para perros han sido un éxito tremendo.

De todas estas maneras, entre otras, le comunico a nuestra comunidad mis valores principales y planifico el futuro que deseamos ver.

Y ahora, vuelvo a pedirle su voto.

Ha confiado en mi con West Hollywood. Por favor continúen enviándome sus ideas sobre cómo podemos crear la Ciudad de West Hollywood que todos queremos.

Comuníquense conmigo enviando un correo electrónico a ourweho@me.com o un mensaje de texto / llame a mi celular al 310.498.5783. www.ourweho.com

Esta es nuestra ciudad. Sigamos viviendo. Bajo nuestras condiciones.

STATEMENT OF TOM DEMILLE
CANDIDATE FOR MEMBER OF THE CITY COUNCIL
WEST HOLLYWOOD CITY GENERAL MUNICIPAL ELECTION

Age: 63

Occupation: Artist

Tom Demille, a 30 year resident and my 5th time to run for this office.

West Hollywood was founded by residents for residents to control rent prices and quality of life. Over the years I have witnessed to erosion of that very action.

Communication with our residents is at an all time low.

Trust in our leaders is essential.

With 20 years of public service, being the conscience of our community.

Graduate of Los Angeles County Sheriff Dept., Community Policing and National Night Out block captain for 5 years. And served on the Disabilities Board.

I have always considered the residents of West Hollywood my family, and will never forget that when elected to fight for you.

As I walk our city I can see that our sidewalks are broken, residents don't walk our streets because they don't feel safe. That stops on March 5th 2019, I will vote to install CCTV in our city to protect our residents and visitors.

In the next 5 years our city will be 60% seniors, So we will have to triple the social service budget to meet our demands.

100 micro units at Crescent heights and Santa Monica blvd will insure we are still providing opportunities to our young, and to help the rest of our citizens.

West Hollywood residents don't want to be lied to.

Our residents need more opportunity to guide our council in projects that affect our city in the negative.

At our city council meetings, the things that are most important to our citizens end up on consent calendar without any public comment.

A good start to recovery is to have town hall meetings to hear our resident's ideas and concerns.

(Continued on next page)

STATEMENT OF TOM DEMILLE (Continued)

Our boards and commissions are stacked with residents that have been there for much too long.

I ask for your vote on March 5th, I believe I have what it takes to bring us back together as a city who listens to its residents.

I will strive to give 100% of my efforts to bring our city back to basics and to make our city the cleanest and safest city on the west side.

Thank you for your vote, and your trust.

Let's do this together, and to put our residents first.

Tom Demille

DECLARACIÓN DE TOM DEMILLE
CANDIDATO PARA MIEMBRO DEL CONCEJO MUNICIPAL
ELECCIÓN MUNICIPAL GENERAL DE LA CIUDAD DE
WEST HOLLYWOOD

Edad: 63

Ocupación: Artista

Tom Demille, residente de 30 años, y es la 5ª vez que me postulo para este cargo.

West Hollywood fue fundada por los residentes para los residentes para controlar los precios de los alquileres y la calidad de vida. A lo largo de los años, he sido testigo de la erosión de aquellas medidas.

La comunicación con nuestros residentes es escasa todo el tiempo.

Es esencial confiar en nuestros líderes.

Con 20 años de servicio público, siendo la conciencia de nuestra comunidad.

Graduado del Departamento de Alguaciles Adjuntos del Condado de Los Angeles, Policía Comunitaria y fui capitán de manzana de National Night Out (Noche Nacional del Vecindario) durante 5 años, Además, serví en la Junta para personas con discapacidades.

Siempre he considerado a los residentes de West Hollywood como si fueran mi familia y nunca lo olvidaré cuando me elijan para luchar por ustedes.

Al caminar por nuestra ciudad, puedo ver que nuestras aceras se encuentran en mal estado, los residentes no caminan por la calle porque no se sienten seguros. Eso se terminará el 5 de marzo de 2019. Votaré para instalar CCTV (televisilancia) en nuestra ciudad para proteger a nuestros residentes y visitantes.

En los próximos 5 años, el 60% de nuestra ciudad estará constituido por personas mayores. Así que tendremos que triplicar el presupuesto para los servicios sociales para cumplir nuestras demandas.

100 microunidades de Crescent Heights y Santa Monica blvd asegurarán que continuamos ofreciéndoles oportunidades a nuestros jóvenes y ayudando al resto de nuestros ciudadanos.

Los residentes de West Hollywood no quieren que les mientan.

Nuestros residentes necesitan más oportunidades para guiar a nuestro concejo hacia proyectos que aborden la parte negativa de nuestra ciudad.

En las reuniones de nuestro concejo municipal, lo más importante para nuestros ciudadanos termina en una agenda preestablecida sin observaciones públicas.

Un buen comienzo hacia la recuperación es tener reuniones en el ayuntamiento para escuchar las ideas y preocupaciones de nuestros residentes.

(Continúa en la página siguiente)

DECLARACIÓN DE TOM DEMILLE (Continuación)

Nuestras juntas y comisiones están repletas de residentes que han estado en esos cargos durante demasiado tiempo.

Le pido su voto el 5 de marzo. Creo que tengo lo que se necesita para volver a unirnos como una ciudad que escucha a sus residentes.

Me esforzaré para dar el 100% de mí para volver a los fundamentos y hacer de nuestra ciudad la más limpia y segura de la parte oeste.

Gracias por su voto y su confianza.

Hagamos esto juntos y pongamos a nuestros residentes en primer lugar.

Tom Demille

STATEMENT OF BRENDAN HOOD
CANDIDATE FOR MEMBER OF THE CITY COUNCIL
WEST HOLLYWOOD CITY GENERAL MUNICIPAL ELECTION

Occupation: Marketing Analytics Director

West Hollywood was founded thirty-four years ago as a beacon for economic and social justice. In order to protect that legacy for the next thirty years the city must take bold action. Though at the center of the second largest city in the country, and suffering from a decades-long housing crisis, West Hollywood continues to place strict limits on the density of housing. This imposes unnecessary economic, social, and environmental costs on all of us, costs felt most acutely by those least equipped to bear them. This must change. As your city councilmember I will support changes to existing zoning and inclusionary housing policies to spur more construction of both market rate and affordable housing, and defend rent control. West Hollywood also lacks sufficient public transportation. But in the coming months it will have the rare opportunity to change that for good. LA Metro is currently finalizing its plans for the Crenshaw Line Northern Extension. If routed through the heart of West Hollywood it could cut travel times across the region in half, save residents thousands of dollars on car expenses, and boost sales for local businesses. But to make this happen it will require creativity and more importantly courage from our leaders. As your city councilmember I will make this a top priority. West Hollywood is also in the midst of a crisis of homelessness. To have any chance at solving this issue we must first end policies that exacerbate the problem. A lack of affordable housing and poor public transit push many people onto the streets, people who would otherwise not be homeless if they could afford housing with access to cheap, reliable public transportation. We must also expand services that assist those whose homelessness is caused by more implacable issues like mental health and LGBTQ+ discrimination. As your city councilmember I will push to the city do so. Finally, I realize that West Hollywood cannot solve these issues, and others, alone. It will take the cooperation of local governments and agencies from across the region. But like with so many issues in the past when West Hollywood takes a leadership role change happens. If you believe it is time for West Hollywood to lead once again then I ask for your support on March 5th. To learn more about my campaign please visit www.brendanhood.com.

DECLARACIÓN DE BRENDAN HOOD
CANDIDATO PARA MIEMBRO DEL CONCEJO MUNICIPAL
ELECCIÓN MUNICIPAL GENERAL DE LA CIUDAD DE
WEST HOLLYWOOD

Ocupación: Director de Análisis de Mercadotecnia

West Hollywood fue fundada hace treinta y cuatro años como punto de referencia económico y de justicia social. Para proteger ese legado durante los próximos treinta años, la ciudad debe tomar medidas vigorosas. A pesar de estar en el centro de la segunda ciudad más grande del país y sufriendo una crisis de vivienda durante décadas, West Hollywood continúa imponiendo límites estrictos a la densidad de las viviendas. Esto nos impone a todos costos económicos, sociales y medioambientales innecesarios, que los sienten con mayor intensidad aquellos que están menos equipados para soportarlos. Esto debe cambiar. Como miembro del Concejo Municipal, apoyaré los cambios para la zonificación actual y políticas de vivienda inclusivas, para estimular la construcción de más viviendas asequibles y por debajo del índice del mercado, y defender el control de los alquileres. West Hollywood también carece de transporte público suficiente. Pero en los próximos meses, tendrá la oportunidad excepcional de cambiar eso para bien. Actualmente, el LA Metro está terminando sus planificaciones para la extensión norte de la línea Crenshaw. Si se traza a través del centro de West Hollywood, podría reducir a la mitad las horas de viaje por la región, ahorrarles a los residentes miles de dólares en gastos del automóvil y impulsar las ventas a los comercios locales. Sin embargo, para hacer que esto suceda, se necesitará creatividad y, aún más importante, coraje de parte de nuestros líderes. Como miembro del Concejo Municipal, voy a hacer que esto sea mi principal prioridad. West Hollywood también se encuentra en el medio de una crisis de indigencia. Para tener alguna oportunidad para resolver este problema, primero debemos acabar con las políticas que exacerban el problema. La ausencia de viviendas asequibles y el transporte público deficiente impulsan a las personas a vivir en la calle, personas que, de otra manera, no serían indigentes si pudieran adquirir una vivienda con acceso a un transporte público económico y confiable. También debemos ampliar los servicios que ayudan a aquellos cuya situación de indigencia es causada por problemas más implacables como salud mental y discriminación LGBTQ+ (Lesbianas, Homosexuales, Bisexuales, Transgéneros, Queers y más). Como miembro del concejo municipal, promoveré todo eso. Por último, me doy cuenta que West Hollywood no puede resolver estos problemas, ni otros, sola. Implicará la cooperación de los gobiernos y agencias locales de toda la región. Pero, como con muchos otros problemas anteriores, cuando West Hollywood toma el liderazgo, los cambios suceden. Si cree que es tiempo de que West Hollywood tenga la delantera nuevamente, entonces le pido su apoyo el 5 de marzo. Para obtener más información sobre mi campaña, por favor visite www.brendanhood.com

STATEMENT OF LINDSEY P. HORVATH

CANDIDATE FOR MEMBER OF THE CITY COUNCIL

WEST HOLLYWOOD CITY GENERAL MUNICIPAL ELECTION

Occupation: West Hollywood Councilmember

It has been my highest honor to serve you on the West Hollywood City Council. When you elected me four years ago, I promised to protect the foundation of our great city – our diversity and exceptional quality of life. As an eleven-year West Hollywood resident and small business owner, I understand how vital sustaining a safe, diverse city with ample job opportunities and affordable housing is to our community.

That's why I'm proud of what we've been able to accomplish together over the last four years. Together, we've worked to: (a) Improve city services and reform our city by making our government more transparent and accessible, (b) Keep our communities safe for all of our residents by prioritizing community policing, (c) Preserve and build more affordable housing, (d) Limit and mitigate the impact of development on our communities, (e) Improve public transit by bringing the Metro Line to WeHo ahead of schedule, and (f) Find solutions to care for and house our growing homeless population.

And most importantly, I am proud to have been your voice and advocate on the West Hollywood City Council.

Over the next four years, I will continue to control overdevelopment and protect the unique identities of our neighborhoods, focusing on making them more livable and walkable. I will continue to deliver strong fiscal management of our city budget, prioritizing investment in public transit, affordable housing, and public safety. And I will continue to champion open, accessible, and accountable city government, ensuring it serves all generations in WeHo.

I'm proud of what we've accomplished by working together and to have earned the support of Governor Gavin Newsom, State Senator Ben Allen, State Assemblymember Richard Bloom, Los Angeles Mayor Eric Garcetti, Los Angeles County Supervisor Sheila Kuehl, County Assessor Jeffrey Prang, West Hollywood Mayor John J. Duran, Mayor Pro Tempore John D'Amico, Councilmember John Heilman, former Mayor & Councilmember Abbe Land, and an exceptionally broad coalition including renters, homeowners, small business owners, environmental and neighborhood leaders, seniors, LGBTQ activists, and young families.

I hope you will consider voting to re-elect me to the West Hollywood City Council. To learn more about our campaign for WeHo, go to: LindseyHorvath4WeHo.com

DECLARACIÓN DE LINDSEY P. HORVATH
CANDIDATA PARA MIEMBRO DEL CONCEJO MUNICIPAL
ELECCIÓN MUNICIPAL GENERAL DE LA CIUDAD DE
WEST HOLLYWOOD

Ocupación: Miembro del Concejo de West Hollywood

Ha sido mi mayor honor servirlos en el Concejo Municipal de West Hollywood. Cuando me eligieron hace cuatro años, prometí proteger la fundación de nuestra gran ciudad - nuestra diversidad y excepcional calidad de vida. Como residente desde hace once años de West Hollywood y propietaria de una pequeña empresa, comprendo lo vital que es para nuestra comunidad mantener una ciudad segura y diversa con abundantes oportunidades laborales y viviendas asequibles.

Es por ello que estoy orgullosa de lo que hemos podido lograr juntos a lo largo de los últimos cuatro años. Juntos, hemos trabajado para: (a) Mejorar los servicios de la ciudad y mejorar la ciudad mediante la transparencia y accesibilidad de nuestro gobierno, (b) Mantener a salvo a nuestras comunidades para todos nuestros residentes, priorizando los servicios policiales comunitarios, (c) Preservar y construir más viviendas asequibles, (d) Limitar y mitigar el impacto del desarrollo en nuestras comunidades, (e) Mejorar el tránsito público, haciendo llegar a WeHo la Metro Line antes de lo previsto, y (f) Encontrar soluciones para proporcionarles cuidado y vivienda a nuestra creciente población de indigentes.

Y, lo que es aún más importante, estoy orgullosa de haber sido su voz y defensora en el Concejo Municipal de West Hollywood.

A lo largo de los próximos cuatro años, continuaré controlando el exceso de urbanización y protegeré las identidades únicas de nuestros vecindarios, enfocándome en hacer que sean lugares donde se pueda vivir y caminar. Continuaré ofreciendo una sólida administración fiscal del presupuesto de nuestra ciudad, priorizando la inversión en el transporte público, las viviendas asequibles y la seguridad pública. Y continuaré defendiendo que el gobierno de la ciudad sea transparente, accesible y responsable, garantizando que sirva a todas las generaciones de WeHo.

Estoy orgullosa de lo que hemos logrado al trabajar juntos y por haber obtenido el apoyo del Gobernador Gavin Newsom, el Senador Estatal Ben Allen, el Miembro de la Asamblea Estatal Richard Bloom, el Alcalde de Los Angeles Eric Garcetti, la Supervisora del Condado de Los Angeles Sheila Kuehl, el Tasador del Condado Jeffrey Prang, el Alcalde de West Hollywood John J. Duran, el Alcalde Interino John D'Amico, el Miembro del Concejo John Heilman, la Ex Alcaldesa y Miembro del Concejo Abbe Land, y una coalición excepcionalmente vasta que incluye inquilinos, propietarios de casas, propietarios de pequeñas empresas, líderes del medio ambiente y vecindarios, personas mayores, activistas de LGBTQ (Lesbianas, Homosexuales, Bisexuales, Transgéneros y Queers) y familias jóvenes.

Espero que consideren votar para reelegirme para el Concejo Municipal de West Hollywood. Para obtener más información sobre nuestra campaña para WeHo, visite: LindseyHorvath4WeHo.com.

STATEMENT OF JAMES DUKE MASON
CANDIDATE FOR MEMBER OF THE CITY COUNCIL
WEST HOLLYWOOD CITY GENERAL MUNICIPAL ELECTION

Age: 26

Occupation: Public Relations Specialist

My name is James Duke Mason, and I'm running for City Council to bring a new generation of leadership to City Hall. With the gridlock in Washington, it's the local communities around our country where real progress and innovation can take place, and we have that opportunity here in West Hollywood.

I've been passionately involved in public service from a young age. When I was 16, I served as a page in the U.S. House of Representatives. At 17 I was the first openly gay president of my high school's student council. At 20 I served on the board of the LGBT media organization Outfest, the youngest board member in their 36-year history.

In 2015, at the age of 22, I ran for City Council for the first time, and though I didn't win, it led to other opportunities to serve the community. For almost 3 years I served on the board of the West Hollywood Community Housing Corporation, which builds a lot of the affordable housing in and around our city. For the last 3 years I've served as a city official on the Lesbian & Gay Advisory Board, including as co-chair from 2017 to 2018. In 2017 I was one of the founding co-organizers of the L.A. Pride Resist March.

Starting at the age of 17 I have worked as a writer for The Huffington Post, The Advocate, Out, Queerty, The Hollywood Reporter and other publications. I have also worked as a public relations consultant for entertainment clients as well as for non-profits such as the WeHo-based organization Mercy For Animals, which is dedicated to preventing cruelty to animals and promoting compassionate food choices and policies.

I'm hoping to win this election so I can use my unique skills and experiences to help lead the way on tackling some of the biggest challenges facing our city, state and country: expanding affordable housing, ending chronic homelessness, supporting small businesses, ensuring that our seniors can age in place with stability and security. Those are just a few of the priorities I will focus on if I'm elected.

For more information please visit my website www.jamesdukemason.com, or feel free to email me at jamesdukemason@gmail.com.

I hope to earn your vote on Election Day- March 5th, 2019. Thank you!

DECLARACIÓN DE JAMES DUKE MASON
CANDIDATO PARA MIEMBRO DEL CONCEJO MUNICIPAL
ELECCIÓN MUNICIPAL GENERAL DE LA CIUDAD DE
WEST HOLLYWOOD

Edad: 26

Ocupación: Especialista en Relaciones Públicas

Mi nombre es James Duke Mason, y me estoy postulando para el Concejo Municipal para aportarle una nueva generación de liderazgo al Ayuntamiento. Con la paralización en Washington, es en las comunidades locales de los alrededores de nuestro país en donde puede producirse un progreso e innovación reales, y tenemos esa oportunidad aquí en West Hollywood.

Desde pequeño, he participado fervientemente en el servicio público. Cuando tenía 16, serví como un buscaperonas en la Cámara de Representantes de los Estados Unidos. A los 17, fui el primer Presidente abiertamente gay del concejo de estudiantes de mi escuela secundaria. A los 20, serví en la Junta de la organización de medios de comunicación LGBT (Lesbianas, Homosexuales, Bisexuales y Transexuales) Outfest, siendo el miembro de la junta más joven en su historia de 36 años.

En 2015, a los 22 años de edad, me postulé por primera vez para el Concejo Municipal y, aunque no gané, se generaron otras oportunidades para servir a la comunidad. Por casi 3 años, presté mis servicios en la Junta de la Corporación de Vivienda Comunitaria de West Hollywood, que construye gran cantidad de las viviendas asequibles en toda nuestra ciudad. Durante los últimos 3 años, he servido como funcionario municipal en la Junta Asesora para Lesbianas y Gays, incluido como copresidente desde 2017 hasta 2018. En 2017, fui uno de los coorganizadores fundadores de la Marcha del Orgullo Gay en L.A.

Desde los 17 años, he trabajado como escritor para The Huffington Post, The Advocate, Out, Queerty, The Hollywood Reporter y en otras publicaciones. También he trabajado como consultor de relaciones públicas para clientes de la industria del entretenimiento, así como también para organizaciones sin fines de lucro, como la organización Mercy for Animals (Misericordia para los Animales) con sede en WeHo, que se dedica a prevenir la crueldad contra los animales y promover opciones y políticas alimenticias compasivas.

Espero ganar esta elección para poder usar mis habilidades y experiencias únicas para ayudar a allanar el camino para abordar algunos de los desafíos más grandes que enfrenta nuestra ciudad, nuestro estado y país: incrementar la cantidad de viviendas asequibles, terminar con la indigencia crónica, apoyar a las pequeñas empresas, garantizar que las personas mayores puedan envejecer con estabilidad y seguridad. Estas son simplemente algunas de las prioridades en las que me enfocaré si me eligen.

Para obtener más información, por favor visiten mi sitio web www.jamesdukemason.com o siéntanse libres de enviarme un correo electrónico a jamesdukemason@gmail.com.

Espero recibir su voto en el Día de las Elecciones - 5 de marzo de 2019. ¡Gracias!

STATEMENT OF LAUREN MEISTER
CANDIDATE FOR MEMBER OF THE CITY COUNCIL
WEST HOLLYWOOD CITY GENERAL MUNICIPAL ELECTION

Occupation: West Hollywood Councilmember

After nearly two decades as a neighborhood advocate, I was elected to the West Hollywood City Council on March 3, 2015. As your Councilmember, I have worked on:

- 1) Introducing initiatives to assist older adults facing housing affordability challenges, strengthen our Rent Stabilization Ordinance, and develop policies requiring accessible design features in affordable housing;
- 2) Establishing West Hollywood as a safe haven for LGBTQ asylum seekers, and providing the LGBTQ community with increased access to healthcare resources;
- 3) Initiating a Needs Assessment study to help inform Council, staff and service providers on how best to allocate funding for social services for West Hollywood's homeless population;
- 4) Promoting neighborhood-friendly planning and land use policies, raising the bar on design standards, environmental programs and sustainability, increasing community engagement and transparency, and developing more stringent regulations for animal grooming facilities;
- 5) Implementing programs such as the Eastside Parkway Beautification Pilot, Public Access Defibrillation Program, Homeless Services Donation Meters, Commercial Sidewalk Cleaning, Construction Fence Art, Free Sunscreen at City Parks Pilot, and "Don't Leave Children or Pets in Parked Cars" Education Campaign.

I've also advocated for our small businesses that serve our residential neighborhoods by putting forward a Small Business Initiative, including a Small Business Task Force.

As West Hollywood Mayor from April 2016 to May 2017, I joined with mayors from across the nation to show support for preserving the Affordable Care Act and protecting immigrant and refugee communities, and I initiated an item to develop socially conscious banking policies.

(Continued on next page)

STATEMENT OF LAUREN MEISTER (Continued)

A resident of West Hollywood for nearly 30 years, I have been both a renter and a homeowner in the city. Professionally, I am the sole proprietor of my own marketing research firm based in West Hollywood. My parents, sister, and rescue dog, Spike, also call West Hollywood home.

We all love West Hollywood and hope to protect what makes our city special. As your City Councilmember, I will continue to make our residents and our neighborhoods my top priority.

The next few years will be challenging for the City of West Hollywood. Homelessness, public safety concerns, more traffic-generating development in the pipeline – all will require an analytical approach, an in-depth understanding of the community, and a voice of reason. That is why I am running for re-election to the West Hollywood City Council.

I respectfully ask for your vote for re-election to West Hollywood City Council.

DECLARACIÓN DE LAUREN MEISTER
CANDIDATA PARA MIEMBRO DEL CONCEJO MUNICIPAL
ELECCIÓN MUNICIPAL GENERAL DE LA CIUDAD DE
WEST HOLLYWOOD

Ocupación: Miembro del Concejo de West Hollywood

Después de casi dos décadas como defensora del vecindario, el 3 de marzo de 2015 me eligieron al Concejo Municipal de West Hollywood. Como Miembro del Concejo, he trabajado para lo siguiente:

1) Introducir iniciativas para ayudar a que los adultos mayores enfrenten los desafíos relacionados con las viviendas asequibles, fortalecer nuestra Ordenanza para la Estabilización de Renta y desarrollar políticas que requieran características de diseño accesible en las viviendas asequibles;

2) Establecer West Hollywood como un refugio seguro para las personas que buscan asilo para LGBTQ (Lesbianas, Homosexuales, Bisexuales, Transgéneros y Queers) y proporcionarle a la comunidad de LGBTQ mayor acceso a los recursos de los cuidados de la salud;

3) Iniciar un estudio de Evaluación de Necesidades para ayudar a informarles al Concejo, el personal y los proveedores de servicios la mejor manera de asignar los fondos para los servicios sociales para la población de indigentes de West Hollywood;

4) Promocionar una planificación para lograr mejores relaciones en los vecindarios y políticas de uso de tierra, elevando el nivel en los estándares de diseño, programas ambientales y de sustentabilidad, aumentando la participación y transparencia comunitaria y desarrollando regulaciones más exigentes para los establecimientos de cuidado de animales;

5) Implementar programas como Eastside Parkway Beautification Pilot (Piloto de Embellecimiento del Eastside Parkway), Public Access Defibrillation Program (Programa de Acceso Público a Defibriladores), Homeless Services Donation Meters (Parquímetros de Donación para Servicios a los Indigentes), Commercial Sidewalk Cleaning (Limpieza de Aceras Comerciales), Construction Fence Art (Arte en Cercas de Construcción), Free Sunscreen at CityParks Pilot (Piloto de Pantalla Solar Gratuita en Parques de la Ciudad) y la campaña educativa “Don’t Leave Children or Pets in Parked Cars” (“No Deje Niños o Mascotas en Autos Estacionados”).

También he abogado por nuestras pequeñas empresas que sirven a nuestros vecindarios residenciales, presentando una Iniciativa para Pequeñas Empresas, que incluye un Grupo de Trabajo de Pequeñas Empresas.

Como Alcaldesa de West Hollywood desde abril de 2016 hasta mayo de 2017, me reuní con alcaldes de todo el país para demostrar apoyo para la

(Continúa en la página siguiente)

DECLARACIÓN DE LAUREN MEISTER (Continuación)

conservación de la Ley de Cuidados Asequibles y proteger a las comunidades de inmigrantes y refugiados, inicié un artículo para desarrollar políticas bancarias con conciencia social.

Residente de West Hollywood por casi 30 años, en la ciudad he sido tanto inquilina como propietaria de casa. Profesionalmente, soy propietaria única de mi propia firma de investigación de mercadotecnia con sede en West Hollywood. Mis padres, mi hermana y mi perro de rescate, Spike, también le llaman hogar a West Hollywood.

Todos amamos West Hollywood y esperamos proteger lo que hace que nuestra ciudad sea especial. Como su miembro del Concejo Municipal, continuaré haciendo que nuestros residentes y vecindarios sean mi principal prioridad.

Los próximos años serán un desafío para la Ciudad de West Hollywood. La indigencia, los problemas de seguridad pública, el crecimiento en curso de la urbanización que genera más tráfico - todo requerirá un enfoque analítico, una comprensión profunda de la comunidad, y una voz de la razón. Es por ello que me estoy postulando para una reelección para el Concejo Municipal de West Hollywood.

Con todo respeto, le pido su voto para la reelección para el Concejo Municipal de West Hollywood.

STATEMENT OF SHAWN DAVIS MOONEY
CANDIDATE FOR MEMBER OF THE CITY COUNCIL
WEST HOLLYWOOD CITY GENERAL MUNICIPAL ELECTION

Age: 48

Occupation: Senior Living Executive

My love affair with West Hollywood began when I first moved here in 1993. I have fond memories of my first job at the Pacific Design Center, back when it was just the blue and green buildings. I remember being impressed with the friendliness, cleanliness, eclecticism, and how safe it seemed. It was so inclusive and diverse from one end of the city to the other. So many different lifestyles and cultures, I knew it would be a lifelong love affair. Currently I live with my husband Shawn and our cat Jade in a quaint studio apartment in the Norma Triangle.

Now, many years later, I walk around and reminisce of those early years and think about how can we preserve these qualities for future generations while embracing the growth and change of West Hollywood.

For the last twenty years I have been a soldier in the U.S. Army, business owner, entertainer, as well as worked in the hospitality industry. My most rewarding position has been as a General Manager of two retirement communities. As a Senior Living Executive not only did I care for the residents, I also led and mentored a team of young adults. I worked closely with the California Workability program through the school districts. We had an excellent success rate, the young people graduated and either stayed employed with me, or moved on to other jobs and college. For the seniors, I was a friend, councilor, resource, and first responder. This is where I developed my desire to look out for all seniors and the disadvantaged. It is our responsibility to care for our seniors, especially our LGBT seniors who may not have anyone to care for them. Together we can ensure that not only do the seniors of West Hollywood have affordable housing, food, and healthcare, but every resident calling West Hollywood home has access to these basic human dignities.

As a leader for most of life I have learned that not only must you listen to the need of those looking up to you, but you must also show them that you listened. I will be a steward of West Hollywood and preserve its eclectic history as well as serve you fairly.

Please contact me with questions or to let me know what issues are important to you at the email below, or visit the website for more information.

www.shawnmooneyforcitycouncil@gmail.com

www.shawndavismooney.com

DECLARACIÓN DE SHAWN DAVIS MOONEY
CANDIDATO PARA MIEMBRO DEL CONCEJO MUNICIPAL
ELECCIÓN MUNICIPAL GENERAL DE LA CIUDAD DE
WEST HOLLYWOOD

Edad: 48

Ocupación: Ejecutivo de Viviendas para Personas Mayores

Mi historia de amor con West Hollywood comenzó cuando me mudé por primera vez aquí en 1993. Tengo recuerdos agradables de mi primer empleo en el Pacific Design Center, cuando eran solamente los edificios azules y verdes. Recuerdo estar impresionado con la amabilidad, limpieza, eclecticismo, y cuán seguro parecía. Era tan inclusivo y diverso desde un extremo de la ciudad hasta el otro. Tantos estilos de vida y culturas distintas, yo sabía que sería una larga historia de amor. Actualmente vivo con mi marido Shawn y nuestro gato Jade en un apartamento estudio pintoresco en Norma Triangle.

Ahora, muchos años después, le doy vueltas a la reminiscencia de aquéllos primeros años y pienso acerca de cómo nosotros podemos conservar esas cualidades para las generaciones futuras mientras adoptamos el crecimiento y el cambio de West Hollywood.

Por los últimos veinte años fui soldado en el Ejército de los Estados Unidos, propietario de negocio, artista de entretenimientos, así como también trabajé en la industria del hospedaje. Mi puesto más gratificante fue como Gerente General de dos comunidades de retiro. Como Ejecutivo de Viviendas para Personas Mayores no solamente me ocupé de los residentes, también lideré y fui mentor de un equipo de adultos jóvenes. Trabajé muy de cerca en el programa California Workability a través de los distritos escolares. Tuvimos una tasa de éxito excelente, la gente joven se graduó y permanecieron empleados conmigo, o bien se cambiaron a otros trabajos y colegios. Para las personas mayores, fui un amigo, un concejal, un recurso, y un socorrista. Aquí es donde desarrollé mi deseo de cuidar a todas las personas mayores y a los desposeídos. Es nuestra responsabilidad cuidar a nuestras personas mayores, especialmente a nuestras personas mayores LGBT (Lesbianas, Homosexuales, Bisexuales y Transexuales) que puedan no tener a nadie que los cuide. Juntos podemos asegurar que no solamente las personas mayores de West Hollywood tengan viviendas asequibles, comida y cuidados de salud, sino también cada residente que llame a West Hollywood su hogar posea acceso a estas dignidades básicas del ser humano.

Como líder que fui la mayor parte de mi vida, he aprendido que no solamente debemos escuchar las necesidades de aquéllos que nos buscan, sino también debemos demostrarles que los escuchamos. Seré un representante de West Hollywood y conservaré su historia ecléctica así como también le serviré justamente a usted.

Por favor comuníquese conmigo con preguntas o déjeme saber qué asuntos le son importantes al correo electrónico debajo, o visite el sitio web para más información.

www.shawnmooneyforcitycouncil@gmail.com

www.shawndavismooney.com

STATEMENT OF ERIC JON SCHMIDT
CANDIDATE FOR MEMBER OF THE CITY COUNCIL
WEST HOLLYWOOD CITY GENERAL MUNICIPAL ELECTION

Age: 53

Occupation: Retired Certified Fitness Trainer

My name is Eric Jon Schmidt. I am 53 years old. I am a retired Certified Fitness Trainer. I served in The U.S. Army Reserves for six years. I attended Henry Ford Community College and University of Michigan. My major field of study was Sociology. I have and continue to commit much of my life to Volunteer Work. I have been a Resident of West Hollywood for almost 20 years. My main reason for the desire to serve the Residents of West Hollywood is to address local issues which affect the public safety, health and quality of life of all residents.

DECLARACIÓN DE ERIC JON SCHMIDT
CANDIDATO PARA MIEMBRO DEL CONCEJO MUNICIPAL
ELECCIÓN MUNICIPAL GENERAL DE LA CIUDAD DE
WEST HOLLYWOOD

Edad: 53

Ocupación: Entrenador Físico Certificado Jubilado

Mi nombre es Eric Jon Schmidt. Tengo 53 años. Soy Entrenador Físico Certificado Jubilado. Serví en La Reserva del Ejército de Estados Unidos por seis años. Asistí al Colegio Comunitario Henry Ford y a la Universidad de Michigan. Mi campo principal de estudio fue la Sociología. He dedicado y continúo dedicando gran parte de mi vida al Trabajo Comunitario. He sido Residente de West Hollywood por casi 20 años. Mi principal motivo para el deseo de servir a los Residentes de West Hollywood es abordar asuntos locales que afectan la seguridad pública, la salud y a la calidad de vida de todos los residentes.

STATEMENT OF SEPI SHYNE
CANDIDATE FOR MEMBER OF THE CITY COUNCIL
WEST HOLLYWOOD CITY GENERAL MUNICIPAL ELECTION

Age: 41

Occupation: Attorney

For over a decade, West Hollywood has welcomed my lovely wife, furkids and I. I am an Iranian American immigrant, an Attorney, a Reiki Master and Pet Healer, a Member of the City's Lesbian and Gay Advisory Board (LGAB) and an LGBTQ Rights Advocate. I own two small businesses. While my life keeps me busy, it also keeps me aware of our City and her needs; I offer myself as a candidate to help meet those needs.

I witness growing economic displacement in our community due to big development and rising costs. Many small businesses shut down. People of color, women, most LGBTQ people, our Russian residents, seniors and people with disabilities on a fixed income cannot afford to live here anymore. Our City continues to lose its small community feel and our homeless numbers continue to grow.

There are places in our community where people don't feel safe walking at night or crossing the street.

I live in rent-controlled property, and will help strengthen and preserve renter's rights. I want small businesses to thrive in our City. I want residents to know they are safe. I want every segment of our community to be listened to, engaged with, and empowered so that we rebuild the foundation of our diverse community roots.

Certainly, economic growth is critical to fund social services and vital City programs. However, our City budget and spending need better oversight, management and more community input.

I prepared extensively for this role across the years, receiving my B.S. in Accounting and MIS from San Jose State University, and my Juris Doctorate from Golden Gate University School of Law in San Francisco.

My Civil Rights Advocacy spans more than 17 years. I was Co-President of the LGBT Bar Association of Los Angeles in 2008. I led a fundraiser where we raised \$10,000 for "No on Prop 8" and I advocated against Hate Crimes and Prop 8 on CNN.

I subsequently volunteered on the Steering Committee for the Human Rights Campaign. I was Co-Chair of Community Events and the Annual Gala.

(Continued on next page)

STATEMENT OF SEPI SHYNE (Continued)

I served on HRC's Board of Governors and currently serve as Co-Chair of Community Engagement. I advocate for equality and engagement of underserved communities including lesbians, the transgender community, the bisexual community, and communities of color.

I pride myself on co-leading the world's first Bisexual Pride in West Hollywood on behalf of LGAB.

It's time for a Lesbian of Color to help represent West Hollywood's diverse community. I am asking for your vote.

www.sepishyne.com

DECLARACIÓN DE SEPI SHYNE
CANDIDATA PARA MIEMBRO DEL CONCEJO MUNICIPAL
ELECCIÓN MUNICIPAL GENERAL DE LA CIUDAD DE
WEST HOLLYWOOD

Edad: 41

Ocupación: Abogada

Por más de una década, West Hollywood ha bienvenido a mi adorada esposa, mis perros y a mí. Soy inmigrante Irano-Americana, Abogada, Maestra de Reiki y Sanadora de Animales, Miembro de LGAB (Junta Asesora para Lesbianas y Gay) y defensora de los derechos de los LGBTQ (Lesbianas, Homosexuales, Bisexuales, Transgéneros y Queers). Soy propietaria de dos pequeñas empresas. Aunque mi vida me mantiene ocupada, también me mantiene al tanto de nuestra Ciudad y sus necesidades; me postulo como candidata para ayudar a satisfacer esas necesidades.

Soy testigo del creciente desplazamiento económico de nuestra comunidad debido al gran desarrollo y aumento de los precios. Cerraron muchas pequeñas empresas. Las personas de color, las mujeres, la mayoría de las personas LGBTQ, nuestros residentes Rusos, las personas mayores y aquellas con discapacidades y bajos ingresos ya no pueden permitirse vivir aquí. Nuestra Ciudad continúa perdiendo su percepción de pequeña comunidad y la cantidad de indigentes sigue aumentando.

Existen lugares en nuestra comunidad en los que las personas no sienten seguridad para caminar en la noche o cruzar la calle.

Vivo en una propiedad de alquiler controlado y ayudaré a fortalecer y preservar los derechos de los inquilinos. Quiero que las pequeñas empresas tengan éxito en nuestra Ciudad. Quiero que los residentes sepan que están seguros. Quiero que todos los segmentos de nuestra comunidad sean escuchados, tenidos en cuenta y empoderados, para que reconstruyamos los cimientos de los orígenes de nuestra comunidad diversa.

Sin duda, el crecimiento económico es fundamental para fundar programas de servicios sociales y vitales de la Ciudad. Sin embargo, el presupuesto y los gastos de nuestra Ciudad necesitan mejor fiscalización, administración y más contribución de la comunidad.

Me preparé considerablemente para esta función durante años, recibiendo mi Licenciatura en Contabilidad y MIS (Sistemas de Información de Gestión) en la Universidad Estatal de San Jose y mi Doctorado en Jurisprudencia en la Escuela de Leyes de la Universidad Golden Gate de San Francisco.

Mi Defensa por los Derechos Civiles abarca más de 17 años. En 2008, fui Copresidenta del Colegio de Abogados LGBT (Lesbianas, Homosexuales, Bisexuales y Transgénero) de Los Angeles. Lideré una organización recaudadora de fondos en la que recaudamos \$10,000 para “No on Prop 8” y promoví la lucha contra los crímenes de Odio y Prop 8 en CNN.

(Continúa en la página siguiente)

DECLARACIÓN DE SEPI SHYNE (Continuación)

Posteriormente, participé como voluntaria en el Comité Directivo para la Campaña por los Derechos Humanos. Fui Copresidenta de los Eventos Comunitarios y la Gala Anual.

Serví en la Junta de Gobernadores de la HRC (Campaña por los Derechos Humanos) y actualmente sirvo como Copresidenta de Participación Comunitaria. Abogo por la igualdad y participación de las comunidades marginadas, como las lesbianas, la comunidad transgénero, la comunidad bisexual y las comunidades de color.

Me enorgullece codirigir el primer Desfile Bisexual del mundo en West Hollywood en nombre de la LGAB.

Es hora de que una Lesbiana de Color ayude a representar la comunidad diversa de West Hollywood. Les pido su voto.

www.sepishyne.com

STATEMENT OF MARQUITA THOMAS
CANDIDATE FOR MEMBER OF THE CITY COUNCIL
WEST HOLLYWOOD CITY GENERAL MUNICIPAL ELECTION

Age: 45

Occupation: Nonprofit Executive

As Executive Director of the Los Angeles Gay & Lesbian Chamber of Commerce, Marquita Thomas:

Leads the third largest LGBT business advocacy organization in America.

Advises corporate, state and local government leaders on partnering with minority business owners.

Increases access to billions of dollars in government contracts by supporting legislation mandating LGBT inclusion in supplier diversity programs.

Advocates for small business owners at the state and local level.

Stimulates job growth and strengthens small businesses through technical assistance and professional development programs.

As a community activist, Marquita Thomas:

Serves on the City of West Hollywood's Lesbian & Gay Advisory Board as a former Co-Chair and was a member of the City's Lesbian Visibility Committee.

Builds bridges between the LGBTQ+ and African-American communities to promote Civil Rights and equality for all.

Is a KCET Local Hero and has been honored by the Los Angeles LGBT Center.

As your West Hollywood City Councilmember, Marquita Thomas will improve the quality of life for residents by:

Prioritizing our response to the homelessness crisis and increasing the number of professional Mobile Intervention Teams to get unhoused residents off the street and into care.

Expanding mental health and substance abuse programs for the recovery community, nightlife workers, patrons, neighbors and any in need.

Constructing new dog parks in Center City and the Eastside of West Hollywood...because happy pets make peoples' lives better.

(Continued on next page)

STATEMENT OF MARQUITA THOMAS (Continued)

Protecting residential neighborhoods by respecting the General Plan and requiring developers to give more to the community for any concessions they request.

Identifying problem landlords and putting them on notice by enhancing residential Code Compliance services at City Hall.

Defending rent control, approving more affordable housing units and making air conditioning a requirement for every housing unit in West Hollywood.

Candidate Pledge:

West Hollywood is a special place to each of us and I want to keep it that way.

Good enough at City Hall is not good enough for me. I believe we can do better.

Our caring, compassion and community are equaled only by our creativity, innovation and energy, which we must focus on improving residents' quality of life in West Hollywood.

If you agree, I am asking for your vote on March 5th.

/s/ Marquita Thomas

For more information visit www.MarquitaforWestHollywood.com

DECLARACIÓN DE MARQUITA THOMAS
CANDIDATA PARA MIEMBRO DEL CONCEJO MUNICIPAL
ELECCIÓN MUNICIPAL GENERAL DE LA CIUDAD DE
WEST HOLLYWOOD

Edad: 45

Ocupación: Ejecutiva de Organización sin fines de lucro

Como Directora Ejecutiva de la Cámara de Comercio de Gays y Lesbianas de Los Angeles, Marquita Thomas:

Lidera la tercera organización comercial defensora de los LGBT (Lesbianas, Homosexuales, Bisexuales y Transgéneros) más grande de America.

Asesora a líderes corporativos, gubernamentales estatales y locales sobre la asociación con propietarios de negocios minoritarios.

Aumenta el acceso a miles de millones de dólares en los contratos gubernamentales al respaldar leyes que regulen la inclusión de LGBT en programas para promover la diversidad entre los proveedores.

Aboga por los propietarios de pequeñas empresas a nivel estatal y local.

Estimula el crecimiento laboral y fortalece a las pequeñas empresas a través de programas de desarrollo profesional y asistencia técnica.

Como activista comunitaria, Marquita Thomas:

Sirve en la Junta Asesora de Lesbianas y Gays de la Ciudad de West Hollywood como Ex Copresidenta y fue miembro del Comité de Notoriedad Lésbica de la Ciudad.

Construye puentes entre las comunidades LGBTQ+ (Lesbianas, Homosexuales, Bisexuales, Transgéneros, Queers y más) y Afroamericana para promover Derechos Civiles e igualdad para todos.

Es una heroína local de KCET y ha recibido honores del Centro de LGBT de Los Angeles.

Como Miembro del Concejo Municipal de West Hollywood, Marquita Thomas mejorará la calidad de vida de los residentes de las siguientes maneras:

Priorizando nuestra respuesta para la crisis de indigencia y aumentando la cantidad de Equipos profesionales de Intervención Móvil para sacar a los residentes sin hogar de la calle y proporcionarles atención médica.

Ampliando los programas de salud mental y abuso de sustancias para la recuperación de la comunidad, los trabajadores nocturnos, los patronos, los vecinos y todos aquellos que necesiten ayuda.

Construyendo nuevos parques para perros en el Center City y al este de West Hollywood... porque las mascotas felices hacen que las vidas de las personas sean mejores.

(Continúa en la página siguiente)

DECLARACIÓN DE MARQUITA THOMAS (Continuación)

Protegiendo los vecindarios residenciales, respetando el Plan General y exigiéndoles a los urbanizadores que le ofrezcan más a la comunidad por cada concesión que solicitan.

Identificando los problemas con los arrendadores y poniéndolos en aviso mejorando los servicios de Cumplimiento del Código Residencial en el Ayuntamiento.

Defendiendo el control de los alquileres, aprobando más unidades de viviendas asequibles y haciendo que el aire acondicionado sea un requisito para todas las unidades de viviendas de West Hollywood.

Promesa de la Candidata:

West Hollywood es un lugar especial para cada uno de nosotros y quiero que lo siga siendo.

Lo que es suficiente para el Ayuntamiento no es suficiente para mí. Creo que podemos mejorar.

Nuestra preocupación, compasión y comunidad solo se igualan con nuestra creatividad, innovación y energía, y debemos enfocarnos en mejorar la calidad de vida de los residentes de West Hollywood.

Si está de acuerdo, le pido su voto el 5 de marzo.

/f/ Marquita Thomas

Para obtener más información, visite www.MarquitaforWestHollywood.com

CITY ATTORNEY'S IMPARTIAL ANALYSIS OF MEASURE Y

Measure Y was placed on the ballot by the West Hollywood City Council and, if approved by a majority of West Hollywood voters, will amend the City's Municipal Code to impose a local gross receipts tax on the sale of adult-use cannabis and adult-use cannabis products by cannabis businesses operating within the City. Measure Y is a revenue-raising measure only. It does not amend the City's existing cannabis land use or business licensing regulations or otherwise authorize new or additional types of cannabis businesses to operate within the City.

If approved, Measure Y would impose a business tax on every cannabis business operating within the City, regardless of its form, of a maximum of seven and one-half percent (7.5%) of all gross receipts on adult-use cannabis and adult-use cannabis products, except that the business tax would not apply to gross receipts on medical cannabis and medical cannabis products.

If approved, the above tax rate can be increased or decreased by the City Council, provided that the City Council cannot exceed the voter-approved maximum rate of seven and one-half percent (7.5%) of gross receipts. An increase to the maximum tax rate above seven and one-half percent (7.5%) would require approval by the West Hollywood voters at a future election.

Measure Y would be a "general tax." All revenue from this tax would be deposited into the City's General Fund and could be used for general City governmental operations and services. If approved, Measure Y is anticipated to generate approximately \$5,500,000 annually in revenue to the City. Pursuant to state law, a majority of votes cast is required to adopt this general tax.

The City currently allows all of the adult-use cannabis activities proposed to be taxed, subject to issuance of land use approvals and a business license.

A "yes" vote on Measure Y is to approve the cannabis business tax. A "no" vote on Measure Y is to reject the cannabis business tax.

A full copy of the proposed Ordinance is printed in this sample ballot pamphlet.

MICHAEL JENKINS
City Attorney

ARGUMENT IN FAVOR OF MEASURE Y

Our City was an early supporter of legalized cannabis. West Hollywood was among the first in the nation to support medical cannabis, and when the legalization of adult-use cannabis appeared on California ballots, 83% of West Hollywood voters said YES.

Once adult-use cannabis became legal, the City began the process of gathering input from the community to inform the implementation of adult-use cannabis. The input guided the City Council's decision to approve a comprehensive cannabis ordinance including adult-use cannabis businesses in adult-use retail, medical dispensary, on-site consumption and delivery.

This measure would create a new 7.5% tax on gross-receipts from adult-use cannabis businesses. These funds will allow the City to better regulate cannabis businesses and pay for services such as public safety, pedestrian/bike safety, street repair, park improvements, and importantly, housing and services for homeless. **The tax will NOT apply to medical cannabis.**

Increasingly, the State of California has shifted responsibility for many community-serving programs to local cities, such as West Hollywood, while taking away revenues previously allocated to cities. Revenues from the cannabis tax can only be used in West Hollywood for local purposes. Additionally, the measure contains accountability requirements including annual independent financial audits and public review of cannabis revenue spending.

This measure is not a tax increase for all residents; it will only be paid by adult-use cannabis businesses. Many cities have cannabis taxes, including the City of Los Angeles's tax of 10% on adult-use cannabis and 5% on medical cannabis; West Hollywood's rate for adult-use will be 7.5% and there will be no tax for medical. Many patrons of current cannabis retailers are visitors; a cannabis tax will ensure that cannabis businesses benefiting from visitors pay their fair share to fund services that benefit our community.

Please join us in supporting Measure Y.

JOHN J. DURAN
Mayor

JOHN D'AMICO
Mayor Pro Tempore

JOHN HEILMAN
Councilmember

LINDSEY P. HORVATH
Councilmember

LAUREN MEISTER
Councilmember

NO ARGUMENT AGAINST THIS MEASURE WAS SUBMITTED

PROPOSED ORDINANCE OF MEASURE Y

AN ORDINANCE OF THE PEOPLE OF THE CITY OF WEST HOLLYWOOD, CALIFORNIA, AMENDING CHAPTER 3.36 OF TITLE 3 (REVENUE AND FINANCE) OF THE WEST HOLLYWOOD MUNICIPAL CODE TO ESTABLISH A CITY GROSS RECEIPTS TAX OF 7.5% ON ADULT-USE CANNABIS AND ADULT-USE CANNABIS PRODUCTS

THE PEOPLE OF THE CITY OF WEST HOLLYWOOD, CALIFORNIA DO HEREBY ORDAIN AS FOLLOWS:

SECTION 1. The alphabetical list of definition in Section 3.36.030 of Chapter 3.36 of Title 3 (Revenue and Finance) of the West Hollywood Municipal Code is amended to add the following new definitions to read as follows and renumbering the existing alphabetical definitions accordingly:

- A. “Cannabis” has the same meaning as in Section 26001 of the California Business and Professions Code.
- B. “Cannabis Business” means any person, business, organization or facility, regardless of form, whether operating for profit or not for profit, that cultivates, processes, stores, tests, packages, labels, distributes, transports, and/or sells, dispenses or delivers cannabis, cannabis products and/or devices for the use of cannabis or cannabis products, including without limitation Cannabis Adult-Use Retail, Cannabis Commercial Cultivation, Cannabis Consumption Area with On-Site Adult-Use Retail, Cannabis Delivery Services, Cannabis Distribution, Cannabis Manufacturer, Cannabis Microbusiness, Cannabis Mobile Consumption Lounge, and Cannabis Testing Laboratory, as all of those terms are defined in Section 19.90.020 of the municipal code. “Cannabis business” does not include personal medical or adult use cannabis cultivation authorized by State law and this Code. A cannabis business shall not be considered to be a religious, social or charitable organization exempt from the payment of business taxes under this Chapter.
- C. “Cannabis Products” has the same meaning as in Section 11018.1 of the California Health and Safety Code.

SECTION 2. A new subsection (n) is added to Section 3.36.040 of Chapter 3.36 of Title 3 (Revenue and Finance) of the West Hollywood Municipal Code to read as follows:

n. Cannabis Business. Any person who engages in a Cannabis Business of selling cannabis, cannabis products and/or devices for the use of cannabis or cannabis products for adult-use shall pay an annual business tax of 7.5% of

(Continued on next page)

PROPOSED ORDINANCE OF MEASURE Y (Continued)

gross receipts on the adult-use cannabis and adult-use cannabis products. No business tax shall be applied to the gross receipts on medical cannabis and medical cannabis products. If a cannabis business is engaged in retail sales and/or delivery of both medical and adult-use cannabis, it shall only be responsible for paying the tax on the gross receipts on the adult-use cannabis and adult-use cannabis products provided that the cannabis business identifies to the City, by reasonable and verifiable standards, the portions of its gross receipts that are tied to medical cannabis and those that are tied to adult-use cannabis, through the cannabis business' books and records kept in the regular course of business, and in accordance with generally accepted accounting principles, and not specifically created and maintained for tax purposes. The cannabis business has the burden of proving the proper apportionment of taxes under this subsection. No cannabis business shall be deemed to be exempt from the payment of the taxes identified above by any other provision of this Code, unless expressly exempted under this Chapter. This tax is a general tax, the revenues from which may be used for unrestricted general revenue purposes of the City. The terms herein shall be as defined in the West Hollywood Municipal Code, and if not found in the Code, as defined in State law.

1. The People of the City of West Hollywood affirm that the following actions shall not constitute an increase of the maximum rate or methodology of the tax requiring subsequent voter approval:

- (a). The restoration of the rate of the tax to a rate that is no higher than the seven and one half percent (7.5%) maximum set by this voter-approved Chapter, if the City Council has previously acted to reduce the rate of the tax;
- (b). An action that interprets or clarifies the methodology of the tax, or any definition applicable to the tax, so long as interpretation or clarification (even if contrary to some prior interpretation or clarification) is not inconsistent with the language of this Chapter;
- (c). The establishment of a class of person or service that is exempt or excepted from the tax or the discontinuation of any such exemption or exception; and
- (d). Resuming collection of the tax imposed by this Chapter, even if the City had, for some period of time, either suspended collection of the tax or otherwise failed to collect the tax, in whole or in part.

(Continued on next page)

PROPOSED ORDINANCE OF MEASURE Y (Continued)

- (e). Changes to the frequency or method of remittance of tax payments to the City and promulgation of administrative guidelines for such remittance.
2. The payment of the tax required pursuant to this subsection shall not be construed as authorizing the conduct or continuance of any illegal business or of a legal business in an illegal manner. Nothing in this Chapter implies or authorizes that any activity connected with the distribution or possession of cannabis is legal unless otherwise authorized and allowed in strict and full conformance to the provisions of State law and this Code.
3. The tax provided for under the provisions of this subsection is not a sales, transactions or use tax and shall not be calculated or assessed as such. The tax established under this subsection shall not be separately identified or otherwise specifically assessed or charged to any customer or client of a cannabis business.
4. This subsection (n) was submitted to the voters for approval. Any amendment to this subsection to increase the tax above the maximum rate of seven and one half percent (7.5%) shall not become effective until such amendment is approved by the voters. The voters expressly authorize the City Council to amend, modify, change, or revise any other provision of this subsection (n) as the City Council deems in the best interest of the City.
5. Pursuant to California Constitution Article XiiiB, the appropriation limit for the City is increased to the maximum extent over the maximum period of time allowed under law consistent with the revenues generated by the tax established by this Chapter.
6. Unless specifically provided otherwise, any reference to a state or federal statute applicable to this subsection shall mean such statute as it may be amended from time to time; provided, that such reference to a statute herein shall not include any subsequent amendment thereto, or to any subsequent change of interpretation thereto by a state or federal agency or court of law, to the extent that such amendment or change of interpretation would require voter approval under California law, or to the extent that such change would result in a tax decrease. Only to the extent voter approval would otherwise be required or a tax decrease would result, the prior version of the statute (or interpretation) shall remain applicable. For any application or situation that would not require voter approval or would not result in a decrease of a tax, provisions of the amended statute (or new interpretation) shall be applicable to the maximum possible extent. To the extent that the City's authorization to collect or impose any tax imposed under this

(Continued on next page)

PROPOSED ORDINANCE OF MEASURE Y (Continued)

subsection is expanded or limited as a result of changes in state or federal law, no amendment or modification of this subsection shall be required to conform the tax to those changes, and the tax shall be imposed and collected to the full extent of the authorization up to the full amount of the tax imposed under this subsection.

SECTION 3. Effective Date. Pursuant to California Constitution Article XIII C §(2)(b) and California Elections Code §9217, if a majority of the qualified voters voting in the election on Measure Y vote in favor of the adoption of such Measure, this ordinance shall be deemed valid and binding and shall be considered as adopted upon the date that the vote is declared by the City Council, and shall go into effect ten (10) days after that date.

SECTION 4. Severability. If any section, sentence, clause or phrase of this ordinance is for any reason held to be invalid or unconstitutional by a decision of any court of competent jurisdiction, such decision shall not affect the validity of the remaining provisions of this ordinance. The People of the City of West Hollywood hereby declare that they would have adopted this ordinance and each section, sentence, clause or phrase thereof, irrespective of the fact that any one or more section, subsections, sentences, clauses or phrases be declared invalid or unconstitutional.

SECTION 5. Certification/Summary. Following the City Clerk's certification that the citizens of West Hollywood have approved this Ordinance, the Mayor shall sign this Ordinance and the City Clerk shall cause the same to be entered in the book of original ordinances of said City; and shall cause the same, or a summary thereof, to be published as required by law.

FULL TEXT OF BALLOT MEASURE B
REFERENDUM CHALLENGING WEST HOLLYWOOD
RESOLUTION NO. 18-5104

A RESOLUTION OF THE CITY COUNCIL OF THE CITY OF WEST HOLLYWOOD AMENDING THE GENERAL PLAN LAND USE MAP TO INCLUDE THE SOUTHERN PORTION OF THE PROJECT SITE IN THE SUNSET SPECIFIC PLAN IN CONJUNCTION WITH A PROPOSED MULTI-USE, OFFICE AND PRIVATE CLUB DEVELOPMENT LOCATED AT 8920 SUNSET BOULEVARD, WEST HOLLYWOOD, CALIFORNIA. (THE ARTS CLUB)

THE CITY COUNCIL OF THE CITY OF WEST HOLLYWOOD HEREBY RESOLVES AS FOLLOWS:

SECTION 1. An application for Master Project (MP15-0046) including General Plan Amendment (GPA15-0002) Specific Plan (SP15-0002); Zoning Map Amendment (ZMA15-0002); Demolition Permit (DMP15-0033); Development Permit (DVP15-0046); Conditional Use Permit (CUP15-0003); Minor Conditional Use Permit (MCUP15-0018); and Administrative Permit (AP15-0039), was filed on December 22, 2015 by 8920 Sunset Boulevard, LLC for the redevelopment of a 20,241 square foot site with a nine-story multi-use commercial building to house The Arts Club, creative office space, and ground floor retail, restaurant with outdoor dining and live music, and art gallery uses. The application was deemed complete on February 23, 2016.

SECTION 2. Notice of the public hearing before the City Council was posted on the site for a period of at least 28 days beginning on July 24, 2018. Notices to surrounding property owners and residents as well as to Neighborhood Watch groups and interested parties including those who have previously commented on the project were mailed on August 9, 2018. The public hearing was noticed in the West Hollywood Independent and Beverly Press newspapers on August 9, 2018. Copies of the staff report and attachments have been on file at the West Hollywood City Hall and West Hollywood Library since August 15, 2018. The City Council properly reviewed and considered this matter at a public hearing on August 20, 2018.

SECTION 3. Pursuant to the California Environmental Quality Act (CEQA), the City circulated a Notice of Preparation of an Environmental Impact Report (EIR) for a period of 33 days from April 28, 2016 through May 31, 2016. A public scoping meeting was held on May 11, 2016. A Draft Environmental Impact Report (EIR) was prepared and a Notice of Availability of the Draft EIR was circulated for a period of 46 days from September 28, 2017 to November 13, 2017. The Final EIR was made public on May 25, 2018. All

(Continued on next page)

FULL TEXT OF BALLOT MEASURE B (Continued)

required notifications were provided pursuant to CEQA and all comment letters were incorporated into the Final EIR.

SECTION 4. In accordance with Section 19.78.060 of the West Hollywood Municipal Code, the City Council hereby finds that this amendment to the General Plan Land Use Map is consistent with the Goals, Objectives, and Policies of the General Plan. The amendment is necessary to allow for consistent zoning over the project site and cohesive development of the property.

The uses that would be permitted on the site are established in the General Plan as desirable for the Sunset Strip, including restaurant and supper club associated with The Arts Club, a business with strong ties to the creative industries, street-fronting, pedestrian friendly retail uses on the ground floor, creative office, and a public art gallery.

The project balances the economic and land use goals of the City, offering creative uses in an iconic design. Inclusion of the southern portion of the property into the Sunset Specific Plan is consistent with land use patterns on the southern side of Sunset Boulevard. On the blocks immediately to the east and west of the project site, the Sunset Specific Plan land use designation extends farther south than the proposed extent for this site. Commercial uses on this portion of the site have been in place since at least 1988, when the current commercial parking area was constructed in conjunction with the existing commercial building. Therefore, the change of this portion of the site from R4 to SSP land use designation is consistent with and will not impede implementation of the objectives, and policies, of the General Plan.

SECTION 5. Based on the foregoing, the City Council hereby amends the General Plan Land Use Map (Figure 3-4 in Chapter 3-15) to incorporate the southern portion of the project site, as described in Attachment A, in the Sunset Specific Plan land use designation.

ATTACHMENT A

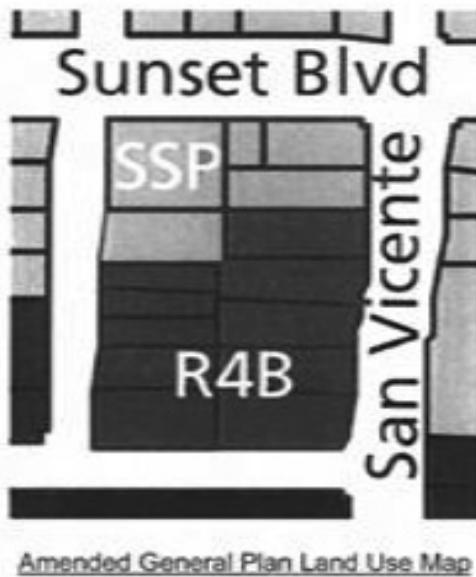
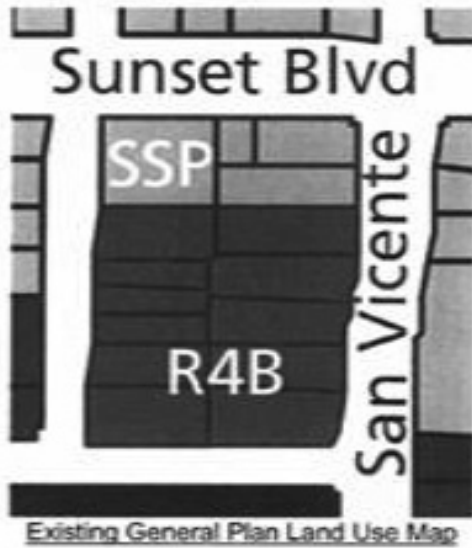

CITY ATTORNEY'S IMPARTIAL ANALYSIS OF MEASURE B

Measure B is a referendum of the West Hollywood City Council's adoption of Resolution No. 18-5104 on September 4, 2018. Resolution No. 18-5104 approved a required entitlement for the Arts Club Project at 8920 Sunset Boulevard. The measure was placed on the ballot as a result of receipt by the City Clerk of a petition signed by the requisite number of voters. Approval of Measure B would affirm Resolution No. 18-5104 and the Arts Club Project will be approved. If the measure fails, then Resolution No. 18-5104 and the Project will be denied.

The Arts Club Project involves construction of a new, nine-story, multi-use commercial building at 8920 Sunset Boulevard. The new, approximately 120,000 square foot building would include an arts club; office, retail, and restaurant uses; a public art gallery; and public rehearsal space for performing arts groups. The northern façade of the building is stepped back at an angle. The project also includes 351 parking spaces located within a subterranean parking structure. In order to approve the project, the City Council placed the southern portion of the property into the Sunset Specific Plan area by adopting Resolution No. 18-5104 amending the City's General Plan Land Use Map. This resolution, the subject of the referendum, was one of several actions taken by the West Hollywood City Council in approving the Arts Club Project, which also included a rezoning of the southern portion of the site into the Sunset Specific Plan area of the Zoning Map, changes to the Sunset Specific Plan to increase allowed height and density on the project site, and approval of demolition, development, conditional use and administrative permits.

Resolution No. 18-5104 was suspended by the filing of the referendum petition. As required by the Elections Code, the City Council chose to place the resolution on the ballot for consideration by the electorate rather than rescind it.

A "yes" vote is in favor of adoption of the resolution and approval of the Arts Club Project.

A "no" vote is against adoption of the resolution and against approval of the Arts Club project.

If this measure receives a majority of "yes" votes, Resolution No. 18-5104 will be approved and the Arts Club Project will be able to proceed; if it receives a majority of "no" votes, the Project will be disapproved.

If this measure fails, there will be an inconsistency between the General Plan Land Use Map and the Zoning Map designations for the southern portion of the project site. The City Council would need to resolve that inconsistency. Further, if the measure fails, the City Council could not again consider Resolution 18-5104 for a year.

A full copy of the Resolution is printed in this sample ballot pamphlet.

MICHAEL JENKINS
City Attorney

ARGUMENT IN FAVOR OF MEASURE B

Last year, our City Council approved the Arts Club, which intends to open its first United States location here in West Hollywood. Founded in 1863 in London by Charles Dickens, the Arts Club creates an atmosphere where artists, musicians, and writers collaborate. The project will include a bistro and music venue, open to the public, where everyone can enjoy food, beverages, and music on the world-famous Sunset Strip. Councilmembers John D'Amico, John Duran, Lindsey Horvath, and Lauren Meister all voted to approve the Arts Club.

The ARTS CLUB WILL REMOVE AND REPLACE THE HUSTLER STORE. Helping to preserve the history and promote the future of the Sunset Strip, it will provide \$13,500,000 IN COMMUNITY BENEFITS, including a public art museum and gallery, which will double as performance space for local musicians, singers, dancers, and artists. \$1,000,000 will be provided to Arts education and scholarships in partnership with West Hollywood Elementary School. Additional measures will help reduce traffic, reduce noise, provide landscaping, and fund affordable housing.

Outside interests came into West Hollywood and threatened this referendum if Arts Club did not give into their demands, which would effectively force employees to pay dues with little voice in the decision. Employees should be able to decide that for themselves, not through some back room deal.

Arts Club employees will be paid well above minimum wage and given extensive benefits, including flexible work hours and child care support. Our community and those future employees need you to support the project so the Community Benefits can happen and employees can start their jobs.

In their desire to preserve the vision of the Sunset Strip, the City approved this amazing project. It is now up to you, the residents of West Hollywood, to support that vision. Please join us **and vote yes – support the City Council's approval of the Arts Club!**

SAM BORELLI

Chair, West Hollywood Human Services Commission

GENEVIEVE MORRILL

President and CEO, West Hollywood Chamber of Commerce

DONNA M. SAUR

Former Member, West Hollywood Public Facilities and Public Safety Commissions

BOBBIE EDRICK

Captain of the Norma Triangle Neighborhood Watch

JOHN A. ALTSCHUL

West Hollywood Planning Commissioner

REBUTTAL TO ARGUMENT IN FAVOR OF MEASURE B

Can you trust the promises of multi-millionaire developers?

The insider lawyers, lobbyists and political operatives involved in the project say they have support of City Council members, but they don't tell you they held a fundraiser for one of the main council supporters less than three months before he voted on the project. When you look into the fine print of these developer promises, you can see a lot of reasons to VOTE NO ON MEASURE B.

Let's look at the fine print of the Measure B rezoning plan:

- Voters get this chance to challenge Measure B because the developers tried to rezone the site to be much larger than the City's General Plan allows. Developers could have built this project without public challenge if they hadn't insisted on it being so tall and dense.
- Developers say the project provides jobs, but don't tell you that approvals EXEMPT CONTRACTED EMPLOYEES FROM THE PROJECT'S MINIMUM WAGE CONDITION, bad for employees and a dangerous precedent for minimum wage laws everywhere.
- The City Council offered these height and density subsidies to hotel developers, but didn't offer similar help to housing developers, so the city didn't TRY to get housing on this site.
- When WEHO residents and hotel workers objected to the rezoning, developers called them "outsiders" and made deceptive anti-union claims, tactics right out of the Republican playbook. This shows you the true politics of the developers.

Reject insider political operatives and their right-wing tactics by VOTING NO ON MEASURE B.

STEVE MARTIN
Former City Council Member

RILEY O'BRIEN
Housing Advocate and WeHo Resident

JORGE SEPERAK
Hotel Worker WeHo Resident

ARGUMENT AGAINST MEASURE B

IF YOU THINK WEST HOLLYWOOD HAS TOO MANY LUXURY HOTELS AND NOT ENOUGH HOUSING, VOTE NO ON MEASURE B.

Voting **NO** protects residential zoning on N Hilldale Avenue and preserve current height and density limits at Hilldale and Sunset. An outside developer wants to radically rezone the site to build a 9-story, 130,000 square foot exclusive club and luxury hotel rooms. If you think our zoning should prioritize housing over luxury hotel developments, **VOTE NO ON MEASURE B.**

West Hollywood is in the midst of an unprecedented hotel construction boom. A consultant's report in 2015 called into doubt the City's ability to absorb the new hotel development in the pipeline at that time. A hotel financial and advisory group said the resulting surplus of rooms would "cannibalize the market" and potentially decrease hotel room tax. Since the 2015 consultant report, even more hotel developments have been approved for by the West Hollywood City Council.

At the same time, the City is suffering from a dire shortage of affordable housing. According to the City's Human Services and Rent Stabilization Department, only 491 units of housing were added in the City of West Hollywood during the period 2013-2015, an increase of only 2% of the total housing stock, which is less than the City's population growth over the same period. Of the units added, 400 were market-rate units and another 18 were single-family homes. Without increased housing development, and especially the creation of affordable housing units, many West Hollywood residents will be priced out of their City.

This site well-suited to multi-unit housing development. If we are going to build 9 stories of something, shouldn't it be housing? That's why more than 2,800 West Hollywood residents signed the petition to give you the chance to vote **NO** on Measure B.

STEVE MARTIN

Former West Hollywood City Councilmember

RILEY O'BRIEN

Housing Advocate and WeHo Resident

JORGE SEPERAK

Hotel Worker and West Hollywood Resident

REBUTTAL TO ARGUMENT AGAINST MEASURE B

Just like some Washington officials, **those opposing the Arts Club will make up anything to win an election.**

The first lie they tell is that the Arts Club is a Hotel. It is not! It is a sustainable, green building to support and encourage Art, Music, Dance, and Entertainment in West Hollywood.

The second lie they tell is that the Arts Club prevents affordable housing. It does not! There's no housing on this site - Hustler is the site's only occupant. If you vote yes, the Arts Club will replace Hustler! Plus, the **Arts Club is contributing \$500,000 to affordable housing.**

Outsiders opposing the Arts Club pushed this referendum, financed by misusing workers' money, because the Arts Club would not force their employees to pay protection money. The Arts Club would rather provide \$13.5 million in Community Benefits to West Hollywood Residents, including \$1 million for Arts education, \$1.25 million to promote artists and performers, and over \$10 million for free arts and rehearsal space.

The Arts Club is a model employer that will pay employees more than the City's living wage, provide health and retirement benefits, and help with childcare. They give reduced-price memberships to local and young artists, and will feature emerging artists in their free, public gallery.

We'll all be proud to have the Arts Club in our community. That's why our neighbors, the City Council, and the Planning Commission overwhelmingly supported the Arts Club.

Haven't we had enough of politicians who say anything to win an election? **Join us and VOTE YES ON MEASURE B!**

BOBBIE EDRICK

Captain, Norma Triangle Neighborhood Watch

ELYSE EISENBERG

President, West Hollywood Heights Neighborhood Association

DONNA M. SAUR

Former Member, West Hollywood Public Safety and Public Facilities Commissions

RUTH WILLIAMS

West Hollywood Public Safety Commissioner

PETER MAYS

Executive Director, Los Angeles Arts Association and Former Commissioner, Arts and Cultural Affairs Commission



Earthquake safety

Some rumblings on preparing for an **EARTHQUAKE**

If you're like most people, after every California earthquake you tell yourself, "I'm going to get prepared for the next one."

Then you don't do a thing about it.

Well, now you can do something about it. Just by reading this page, doing what it says and saving it.

Many earthquake experts in Southern California recommend the following tips to minimize damage in the event of an earthquake.

1. Put together a kit of basic emergency supplies. Include a portable radio, extra batteries, a first aid kit and handbook, wrenches to turn off gas and water valves, and food, water and medication for every member of your family for at least one week.
2. Secure your hot water heater. If your hot water heater falls over during an earthquake, the gas line can rupture and create sparks which can lead to a fire or explosion.
3. Know where your gas, electric and water main shutoffs are and how to shut them off.
4. Secure your tall and heavy furniture. Bookcases, entertainment centers and china cabinets can easily fall over during an earthquake.
5. Put some extra nails in heavy objects that are off the floor such as shelves, mirrors and large picture frames.
6. Hunt for hazard areas in your home. Teach your children to stay away from windows, mirrors and tall furniture.
7. Search for safe place in your home. Show your children how to take cover under a table, desk, or against inside walls.
8. Have a plan to reunite your family after an earthquake. Travel may be difficult and phone lines may be down, so don't drive or call anyone unless it's a real emergency.
9. Check for injury or damage after the shaking stops.
10. Above all, do not panic.

Practicing earthquake drills with your entire family and being prepared with the above instructions will put you in a safer position during any ground motion.

Stop rumbling about how you're going to get ready for "the next one." Prepare for it today. The County of Los Angeles has an Earthquake Survival Program (ESP) with easy monthly preparedness steps.

For more information,
call the Office of Emergency Management
(323) 980-2260 or visit the ESP website at www.espfocus.org

The page would have been blank due to printing layouts. The Registrar-Recorder/County Clerk has used this page to provide additional information.



Recorder/County Clerk

Services:



Birth, Death & Marriage Records



Marriage Licenses



Marriage Ceremonies



Real Estate Transactions



Fictitious Business Name Filings



Notary Oaths

Locations:

Registrar-Recorder/County Clerk

Headquarters

12400 Imperial Hwy.
Norwalk, CA 90650
(800) 201-8999

East Los Angeles

4716 E. Cesar Chavez Ave.
Los Angeles, CA 90022
(800) 201-8999

Lancaster

44509 16th Street West, Suite 101
Lancaster, CA 93534
(800) 201-8999

Beverly Hills

9355 Burton Way, 3rd Floor
Beverly Hills, CA 90210
(800) 201-8999

LAX Courthouse

11701 S. La Cienega Blvd., 6th Floor
Los Angeles, CA 90045
(800) 201-8999

Florence/Firestone

7807 S. Compton Ave., 1st Floor
Los Angeles, CA 90001
(800) 201-8999

Van Nuys

14340 W. Sylvan St.
Van Nuys, CA 91401
(800) 201-8999

lavote.net

The page would have been blank due to printing layouts. The Registrar-Recorder/County Clerk has used this page to provide additional information.



Online services ...fast, easy and convenient!

lavote.net

Quick Links:

- Register to Vote
- Voter Registration Status
- Apply to be a Pollworker
- Campaign Finance Information
- Voting Solutions for All People (VSAP)
- Election Results
- Vote By Mail Application
- Vote By Mail Status
- Vote By Mail Drop-Off Locations
- Early Voting Locations
- Locate Your Polling Place
- View Your Sample Ballot

Connect with us:



@lacountyrcc



Like us



lacountyrcc



Review us



lacountyrcc

The page would have been blank due to printing layouts. The Registrar-Recorder/County Clerk has used this page to provide additional information.



Next time you move... register again to vote!

1. Online at: **lavote.net**
2. Department of Motor Vehicles Offices
3. Post Offices
4. Libraries
5. City Clerk Offices
6. Registrar-Recorder/County Clerk

Please go to **lavote.net** or call toll free 1-800-815-2666, option 2 to find your current registration status and how to obtain a voter registration card.



Be a pollworker

- **Serve your community**
- **Earn up to \$240 for the day**
- **Do your part for democracy**

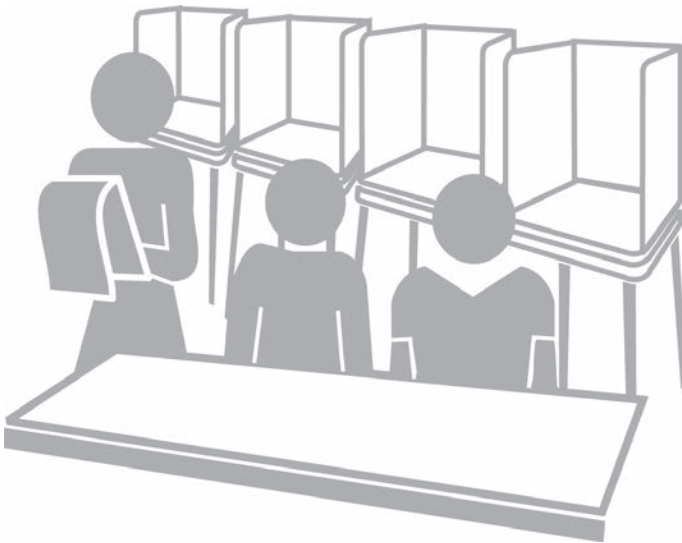

(800) 815-2666, option 7
lavote.net

The page would have been blank due to printing layouts. The Registrar-Recorder/County Clerk has used this page to provide additional information.



Save time and money!

Receive your Official Sample Ballot by email



visit lavote.net to subscribe

The page would have been blank due to printing layouts. The Registrar-Recorder/County Clerk has used this page to provide additional information.



Election information

Call us: 1-800-815-2666

You may obtain information about specific election services by calling toll free and selecting the option number shown for the service requested.

Option 1

Polling place information

Option 2

To register to vote

Verify registration or to request a sample ballot

Vote by mail ballot

Option 3

Multilingual services

Sample ballot translations

Option 4

Election Information

Option 5

Voter fraud/report illegal activity

Option 7

To become a Pollworker

Campaign Financial Disclosure(562) 462-2339

Campaign financial statement filing requirements for candidates, committees and office holders.

TDD (Hearing Impaired)(562) 462-2259

The page would have been blank due to printing layouts. The Registrar-Recorder/County Clerk has used this page to provide additional information.



Accessible polling places

The Los Angeles County Registrar-Recorder/County Clerk's office is committed to providing all voters a private and independent voting experience. To view the Department's accessibility services, go to lavote.net.

Assistive devices at every poll



Audio Ballot Booth



Wheelchair-accessible voting booth



20/20 black felt pen



Easy grip dexterity ball



Magnifying device



Accessible parking signage

Curbside voting

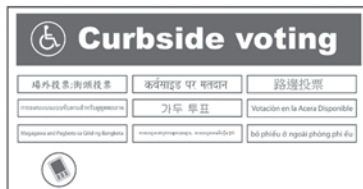

Check for the access symbol on the back cover of this booklet to see if your polling place has an accessible entrance or call the number below.

Important telephone numbers

General information: (800) 815-2666

Polling place accessibility: (800) 815-2666, option 7

CD/Cassette recordings: (800) 815-2666, option 3

TDD: (562) 462-2259

FP-LP01-ENG

LA 012-064

RETURN ADDRESS

DID YOU SIGN YOUR APPLICATION?



Place
1st Class
Postage
Stamp here



**VOTE BY MAIL UNIT
REGISTRAR-RECORDER/COUNTY CLERK
PO BOX 30450
LOS ANGELES CA 90030-0450**





Application to Vote By Mail

**March 5, 2019 - City of West Hollywood
General Municipal Election**

Application must be received by February 26, 2019

Home address: _____
(As registered) Number and Street City Zip Code

Mail my ballot to: _____
(If different from above) Number and Street (or P.O. Box) City Zip Code

I have not applied for a Vote By Mail ballot for this election by any other means.

X _____ () _____
Signature of applicant (Must be signed to be processed) Date Daytime Phone Number

**I want to be a Permanent
Vote By Mail voter.**
You will automatically receive
a ballot and vote by mail
every election

Notice: If the person named on the sample ballot is not at the address, please help keep the voter rolls current and save taxpayer dollars by returning this sample ballot to your mail carrier.

012

Registrar-Recorder/County Clerk
P.O. Box 30450
Los Angeles, CA 90030-0450

Change service requested

Polls open from 7 am to 8 pm

Your polling place is:  



NON PROFIT ORG.
**U.S. POSTAGE
PAID**
LOS ANGELES
COUNTY REGISTRAR-
RECORDER/COUNTY
CLERK