



SOLAR PV STANDARD ELECTRICAL PLAN: CENTRAL/String INVERTER SYSTEMS

SCOPE: Use this plan ONLY for electrical review of utility central/string inverter systems not exceeding a system AC inverter output rating of 10kW on the roof of a one- or two-family dwelling or accessory building. The specific structural and fire requirements are covered in other parts of the California Solar Permitting Guidebook. The photovoltaic system must interconnect to the load side of a single-phase AC service panel of nominal 120/240Vac with a bus bar rating of 225A or less. This plan is not intended for bipolar systems, hybrid systems or systems that utilize storage batteries, charge controllers, trackers, more than two inverters or more than one DC combiner (noninverter-integrated) per inverter. Systems must be in compliance with current California Building Standards Codes and local amendments of the authority having jurisdiction (AHJ). Other Articles of the California Electrical Code (CEC) shall apply as specified in 690.3. For systems beyond this scope or the criteria in this plan, consult the AHJ for details regarding comprehensive process.

MANUFACTURER'S SPECIFICATION SHEETS MUST BE PROVIDED for proposed inverters, modules, combiner/junction boxes, racking systems, and rapid shutdown system or equipment. Installation instructions for bonding and grounding equipment and rapid shutdown systems shall be provided, and local AHJs may require additional details. Listed and labeled equipment shall be installed and used in accordance with any instructions included in the listing or labeling (CEC 110.3). Equipment intended for use with PV system shall be listed for the PV application (CEC 690.4[B]).

Job Address: _____ Permit #: _____

Contractor/Engineer Name: _____ License # and Class: _____

Signature: _____ Date: _____ Phone Number: _____

Total # of Inverters installed: _____ (If more than one inverter, complete and attach the "Supplemental Calculation Sheets" and the "Load Center Calculations" if a new load center is to be used.)

Inverter 1 AC Output Power Rating: _____ Watts

Inverter 2 AC Output Power Rating (if applicable): _____ Watts

Combined Inverter Output Power Rating: _____ ≤ 10,000 Watts

Ambient Temperature Adjustment Factors: select the box for the expected lowest ambient temperature (TL) with the corresponding Ambient Temperature Correction Factor (CF):

1) If T_L is greater than or equal to -5°C
 , $C_f = 1.12$

If T_L is between -6°C and -10°C
 , $C_f = 1.14$

Average ambient high temperature (T_H) ≤ 47°C

Note: For a lower T_L or a higher T_H , this plan is not applicable.



WEST HOLLYWOOD
8300 Santa Monica Boulevard West Hollywood, CA 90069-6216

Building & Safety Division
tel 323.848.6475 fax 323.848.6569

SOLAR PV STANDARD ELECTRICAL PLAN: CENTRAL/String INVERTER SYSTEMS

DC Information:

Module Manufacturer: _____ Model: _____
2) Module V_{oc} (from module nameplate): _____ Volts
3) Module I_{sc} (from module nameplate): _____ Amps Is Module I_{sc} below 9.6 Amps? <input type="checkbox"/> Yes <input type="checkbox"/> No (If No, this plan is not applicable.)
4) Module DC output power under standard test conditions (STC) = _____ Watts (STC)



SOLAR PV STANDARD ELECTRICAL PLAN: CENTRAL/String INVERTER SYSTEMS

5) DC Module Layout

Identify each source circuit (string) for inverter 1 shown on the roof plan with a Tag (e.g. A,B,C,...)	Number of modules per source circuit for inverter 1	Identify, by tag, which source circuits on the roof are to be paralleled (if none, put N/A)
		Combiner 1:
		Combiner 2:
Total number of source circuits for inverter 1: _____		

6) Are DC/DC Converters used? Yes No If No, skip to Step 7. If Yes enter info below.

DC/DC Converter Model #: _____ Max DC Output Current: _____ Amps Max # of DC/DC Converters in an Input Circuit: _____	DC/DC Converter Max DC Input Voltage: _____ Volts Max DC Output Current: _____ Volts DC/DC Converter Max DC Input Power: _____ Watts
---	--

7) Maximum System DC Voltage — Use for systems without DC/DC converters.

A. Module V_{oc} (STEP 2) _____ x # of modules in series (STEP 5) _____ x C_F (STEP 1) _____ = _____ V

Max. Rated Module V_{oc} if $C_F = 1.12$ (Volts)	29.76	31.51	33.48	35.71	38.27	41.21	44.64	48.70	53.57	59.52	66.96	76.53	89.29
Max. Rated Module V_{oc} if $C_F = 1.14$ (Volts)	29.24	30.96	32.89	35.09	37.59	40.49	43.86	47.85	52.63	58.48	65.79	75.19	87.72
Max # of Modules for 600 Vdc	18	17	16	15	14	13	12	11	10	9	8	7	6

Use for systems with DC/DC converters. The value calculated below must be less than DC/DC converter max DC input voltage (STEP 6)

B. Module V_{oc} (STEP 2) _____ x # of modules per converter (STEP 6) _____ x C_F (STEP 1) _____ = _____ V

Max. Rated Module V_{oc} if $C_F = 1.12$ (Volts)	30.4	33.0	35.7	38.4	41.1	43.8	46.4	49.1	51.8	54.5	57.1	59.8	62.5	65.2	67.9	70.5
Max. Rated Module V_{oc} if $C_F = 1.14$ (Volts)	29.8	32.5	35.1	37.7	40.4	43.0	45.6	48.2	50.9	53.5	56.1	58.8	61.4	64.0	66.7	69.3
DC/DC Converter Max DC Input (Step #6) (Volts)	34	37	40	43	46	49	52	55	58	61	64	67	70	73	76	79

8) Maximum System DC Voltage from DC/DC Converters to Inverter — Only required if Yes in Step 6
Maximum System DC Voltage = _____ Volts



SOLAR PV STANDARD ELECTRICAL PLAN: CENTRAL/String INVERTER SYSTEMS

9) Sizing Source Circuit Conductors

Source Conductor Size = Min #10 AWG copper conductor, 90°C wet (USE-2, PV Wire, XHHW-2, THWN-2, RHW-2)
For up to 8 conductors in roof-mounted conduit exposed to sunlight at least ½” from the roof covering. (CEC 310)

Note: For over 8 conductors in the conduit or mounting height of lower than ½” from the roof, this plan is not applicable.

10) Are PV source circuits combined prior to the inverter? Yes No
If No, use Single Line Diagram 1 and proceed to Step 12.
If Yes, use Single Line Diagram 2 and proceed to step 11 after this step.

Is source circuit OCPD required? Yes No
Source circuit OCPD size (if needed): 15 Amps

Are the source circuits combined on the roof? Yes No
If “Yes”, the DC output of the combiner shall have a load break disconnecting means located in the combiner or within 1.8m (6ft) of the combiner (CEC 690.15(c)).

11) Sizing PV Output Circuit Conductors
Sizing strings are combined (answered “Yes” in Step 10).
Output Circuit Conductor Size = Min. #6 AWG copper conductor

12) Inverter DC Disconnect
Does the inverter have an integrated DC disconnect? Yes No If Yes, proceed to Step 13.
If No, the external DC disconnect to be installed is rated for ____Amps (DC) and ____ Volts (DC)

13) Inverter Information
Manufacturer: _____ Model: _____
Max. Continuous AC Output Current Rating: ____Amps
Integrated DC Arc-Fault Circuit Protection? Yes No (If No is selected, this plan is not applicable.)
Grounded or Underground System? Grounded Ungrounded

AC Information:

14) Sizing Inverter Output Circuit Conductors and OCPD
Inverter Output OCPD rating = ____Amps (Table 3)
Inverter Output Circuit Conductor Size = ____AWG (Table 3)

Table 3. Minimum Inverter Output OCPD and Circuit Conductor Size									
Inverter Continuous Output Current Rating (Amps) (Step 14)	12	16	20	24	28	32	36	40	48
Minimum OCPD Size (Amps)	15	20	25	30	35	40	45	50	60
Minimum Conductor Size (AWG, 75° C, Copper)	14	12	10	10	8	8	6	6	6



SOLAR PV STANDARD ELECTRICAL PLAN: CENTRAL/STRING INVERTER SYSTEMS

15) Point of Connection to Utility

Note: Only load side connections are permitted with this plan.

Is the PV OCPD positioned at the opposite end from input feeder location or main OCPD location?

- Yes, use Table 4, row 3 and circle the Max Combined PV System OCPD(s) at 120% based on the busbar rating and main OCPD values.
- No, use Table 4, row 4 and circle the Max Combined PV System OCPD(s) at 100% based on the busbar rating and main OCPD values.

Per 705.12(D)(2)(3): The value circled in Table 4 should be equal to or greater than the OCPD value selected from Table 3 (for a single inverter) or the OCPD value from Step S18 (for two inverters).

Busbar Rating	100	125	125	200	200	200	225	225	225
Main OCPD	100	100	125	150	175	200	175	200	225
Max Combined PV System OCPD(s) at 120% of Busbar Rating	20	50	25	60*	60*	40	60*	60*	45
Max Combined PV System OCPD(s) at 100% Busbar Rating	0	25	0	50	25	0	50	25	0

*This value has been lowered to 60 A from the calculated value to reflect 10 kW AC size maximum.

Reduction of the Main Break is not permitted with this plan.

Inteconnection to center-fed panel boards may be permitted per Informational Bulletin.



SOLAR PV STANDARD ELECTRICAL PLAN: CENTRAL/String INVERTER SYSTEMS

16) Rapid Shutdown

The rapid shutdown initiation device shall be labeled according to CEC 690.56(C), and its location shall be shown on the site plan drawing. The rapid shutdown initiation device may be the inverter output or input circuits' disconnecting means, the service main disconnect, or a separate device as approved by the AHJ. The disconnecting means shall be identified for the purpose, suitable for their environment, and listed as a disconnecting means. A single rapid shutdown initiation device shall operate all disconnecting means necessary to control conductors in compliance with CEC 690.12. Note: Check with the AHJ regarding approval where field verification of reduction of voltage within the time required by CEC 690.12 is performed.

Rapid shutdown shall be provided as required by CEC 690.12 with one of the following methods (Select one):

- The inverter(s) is within 10 feet of the array, and the location of the inverter is such that uncontrolled PV system conductors are no greater than 5 feet of length within the building. A remotely-controlled AC disconnecting means is required immediately adjacent to or as close as practicable to the inverters, and located within 10 feet of the array.
- The inverter(s) is within 10 feet of the array, and the location of the inverter is such that uncontrolled PV system conductors are no greater than 5 feet of length within the building. Reduction of the voltage for the inverter output within the time required by CEC 690.12 shall be verified in the field, or the inverter output is listed to UL 1741 with rapid shutdown capability.
- Remotely-controlled DC disconnecting means are located within 10 feet of the PV array and DC input of the inverter(s), and the locations of the disconnecting means are such that uncontrolled PV system conductors are no greater than 5 feet of length within the building. Reduction of the voltage for the inverter output within the time required by CEC 690.12 shall be verified in the field, or the inverter output is listed to UL 1741 with rapid shutdown capability.
- Remotely-controlled DC disconnecting means is located within 10 feet of the array at the DC input of inverter(s) connected to a module level DC-DC converter circuit where the DC-DC converter circuit meets the requirements for controlled conductors when disconnected from the inverter. Reduction of the voltage for the DC-DC converter output and the inverter output within the time required by CEC 690.12 shall be verified in the field, or the DC-DC converter output and the inverter output are listed to UL 1741 with rapid shutdown capability.
- A UL 1741-listed and identified inverter(s) with input and output rapid shutdown capability supplying module level DC-DC converter circuit where the DC-DC converter circuit meets the requirements for controlled conductors when disconnected from the inverter.
- A UL 1741-listed rapid shutdown system:
 Manufacturer: _____
 Testing Agency Name: _____
 System Model Number: _____
 System Components: _____



WEST HOLLYWOOD
8300 Santa Monica Boulevard West Hollywood, CA 90069-6216

Building & Safety Division
tel 323.848.6475 fax 323.848.6569

SOLAR PV STANDARD ELECTRICAL PLAN: CENTRAL/STRING INVERTER SYSTEMS

17) Grounding and Bonding of Modules and Racking System (select one):

- Racking system listed to UL 2703 using modules identified in the listing.
- Other method subject to AHJ approval



SINGLE-LINE DIAGRAM #1 – NO STRINGS COMBINED PRIOR TO INVERTER

Δ TAG	DESCRIPTION
1	SOLAR PV MODULE / STRING
2	DC/DC CONVERTERS INSTALLED? YES / NO (IF YES, STEPS 6 & 8 REQUIRED)
3	SOURCE CIRCUIT JUNCTION BOX INSTALLED?: YES / NO
4	SEPARATE DC DISCONNECT INSTALLED?: YES / NO
5	INTERNAL INVERTER DC DISCONNECT: YES / NO
6	CENTRAL INVERTER
7	LOAD CENTER INSTALLED?: YES / NO
8	PV PRODUCTION METER INSTALLED?: YES / NO
9	*SEPARATE AC DISCONNECT INSTALLED?: YES / NO
10	CONNECT TO INVERTER #2 (USE LINE DIAGRAM 2)

* Consult with your local AHJ and /or Utility

CHECK A BOX FOR WHETHER SYSTEM IS GROUNDED OR UNGROUNDED:
 GROUNDED (INCLUDE GEC)
 UNGROUNDED

REFER TO STEP 16 FOR RAPID SHUTDOWN DETAILS

FOR UNGROUNDED SYSTEMS:
 - DC OCPD MUST DISCONNECT BOTH CONDUCTORS OF EACH SOURCE CIRCUIT
 - UNGROUNDED CONDUCTORS MUST BE IDENTIFIED PER 210.5(C). WHITE-FINISHED CONDUCTORS ARE NOT PERMITTED.

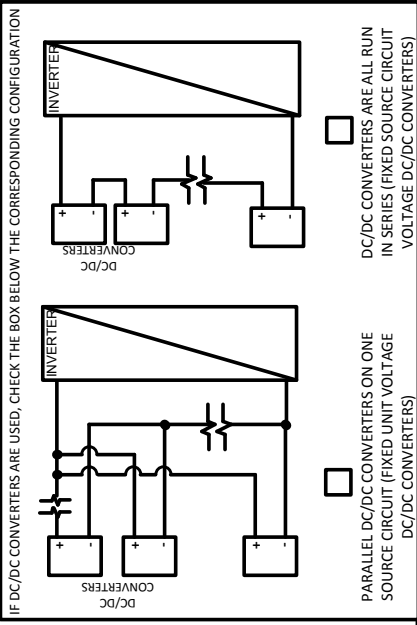
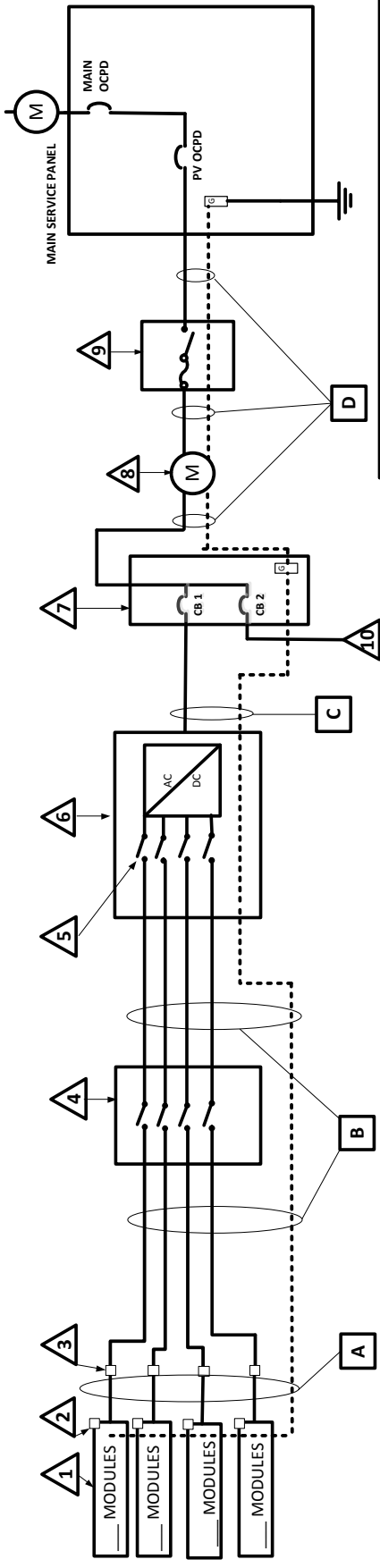

TAG	DESCRIPTION AND CONDUCTOR TYPE	CONDUCTOR/CONDUIT SCHEDULE		
		CONDUCTOR SIZE	NUMBER OF CONDUCTORS	CONDUIT/CABLE TYPE
A	USE-2 <input type="checkbox"/> OR PV-WIRE <input type="checkbox"/>			
B	EGC/GEC:			
C	EGC/GEC:			
D	EGC/GEC:			
	EGC/GEC:			

ENTER "N/A" WHERE SUITABLE FOR WHEN NOT USING CONDUIT OR CABLE AS PERMITTED BY CODE



SINGLE-LINE DIAGRAM #2 – COMBINING STRINGS PRIOR TO INVERTER

Δ TAG	DESCRIPTION
	SOLAR PV MODULE / STRING
	DC/DC CONVERTERS INSTALLED? YES / NO (IF YES, STEPS 6 & 8 REQUIRED)
	SOURCE CIRCUIT JUNCTION BOX INSTALLED? YES / NO
	COMBINER BOX (STEPS 1.1 & 1.2 REQUIRED)
	SEPARATE DC DISCONNECT INSTALLED? YES / NO
	INTERNAL INVERTER DC DISCONNECT? YES / NO
	CENTRAL INVERTER
	LOAD CENTER INSTALLED? YES / NO
	PV PRODUCTION METER INSTALLED? YES / NO
10	*SEPARATE AC DISCONNECT INSTALLED? YES / NO
11	CONNECT TO INVERTER #2 (USE LINE DIAGRAM 4)

* Consult with your local AHJ and /or Utility

CHECK A BOX FOR WHETHER SYSTEM IS GROUNDED OR UNGROUNDED:
REFER TO STEP 16 FOR RAPID SHUTDOWN DETAILS

GROUNDED (INCLUDE GEC)
 UNGROUNDED

FOR UNGROUNDED SYSTEMS:
- DC OCPD MUST DISCONNECT BOTH CONDUCTORS OF EACH SOURCE CIRCUIT
- UNGROUNDED CONDUCTORS MUST BE IDENTIFIED PER 210.5(C). WHITE-FINISHED CONDUCTORS ARE NOT PERMITTED.

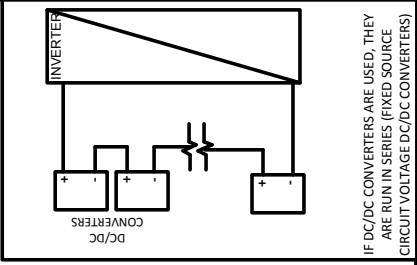
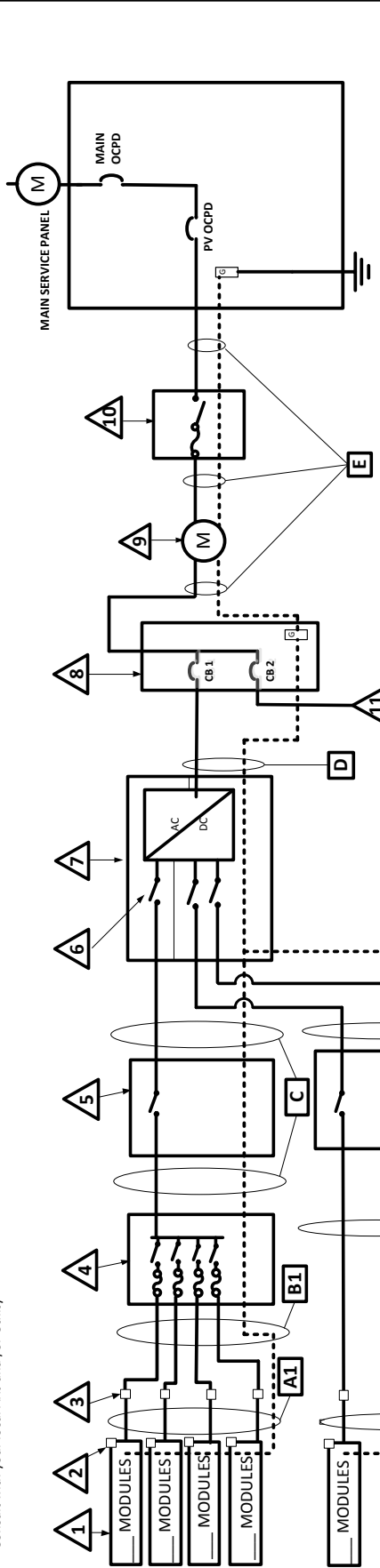

IF DC/DC CONVERTERS ARE USED, THEY ARE RUN IN SERIES (FIXED SOURCE CIRCUIT VOLTAGE DC/DC CONVERTERS)

NON-COMBINED STRINGS CONDUCTOR/CONDUIT SCHEDULE (IF APPLICABLE)			
□ TAG	DESCRIPTION AND CONDUCTOR TYPE	CONDUCTOR SIZE	NUMBER OF CONDUCTORS
A2	USE-2 □ OR PV-WLRE □		
	EGC/GEC:		
B2	EGC/GEC:		

COMBINER CONDUCTOR/CONDUIT SCHEDULE			
□ TAG	DESCRIPTION AND CONDUCTOR TYPE	CONDUCTOR SIZE	NUMBER OF CONDUCTORS
A1	USE-2 □ OR PV-WLRE □		
	EGC/GEC:		
B1	EGC/GEC:		
C	EGC/GEC:		
D	EGC/GEC:		
E	EGC/GEC:		
	EGC/GEC:		

ENTER "N/A" WHERE SUITABLE FOR WHEN NOT USING CONDUIT OR CABLE AS PERMITTED BY CODE



SOLAR PV STANDARD ELECTRICAL PLAN: CENTRAL/STRING INVERTER SYSTEMS

Supplemental Calculation Sheets for Inverter #2 (Only include if second inverter is used)

DC Information:

Module Manufacturer: _____ Model: _____		
S2) Module V_{OC} (from module nameplate): ____ Volts		
S3) Module I_{SC} (from module nameplate): ____ Amps Is Module I_{SC} below 9.6 Amps? <input type="checkbox"/> Yes <input type="checkbox"/> No (If No, this plan is not applicable.)		
S4) Module DC output power under standard test conditions (STC) = _____ Watts (STC)		
S5) DC Module Layout		
Identify each source circuit (string) for inverter 1 shown on the roof plan with a Tag (e.g. A,B,C,...)	Number of modules per source circuit for inverter 1	Identify, by tag, which source circuits on the roof are to be paralleled (if none, put N/A)
		Combiner 1:
		Combiner 2:
Total number of source circuits for inverter 1: _____		
S6) Are DC/DC Converters used? <input type="checkbox"/> Yes <input type="checkbox"/> No If No, skip to Step S7. If Yes, enter info below.		
DC/DC Converter Model #: _____ Max DC	DC/DC Converter Max DC Input Voltage: _____ Volts	
Output Current: _____ Amps Max	Max DC Output Current: _____ Volts	
# of DC/DC Converters in an Input Circuit: _____	DC/DC Converter Max DC Input Power: _____ Watts	



SOLAR PV STANDARD ELECTRICAL PLAN: CENTRAL/STRING INVERTER SYSTEMS

S7) Maximum System DC Voltage

Use Systems without DC/DC converters.

A. Module V_{oc} (STEP S2) = _____ x # of modules in series (STEP S5) _____ x C_f (STEP 1) _____ = _
_____ V

Table S1. Maximum Number of PV Modules in Series Based on Module Rated V_{oc} for 600Vdc Rated Equipment (CEC 690.7)													
Max. Rated Module V_{oc} (*1.12) (Volts)	29.76	31.51	33.48	35.71	38.27	41.21	44.64	48.70	53.57	59.52	66.96	76.53	89.29
Max. Rated Module V_{oc} (*1.14) (Volts)	29.24	30.96	32.89	35.09	37.59	40.49	43.86	47.85	52.63	58.48	65.79	75.19	87.72
Max # of Modules for 600 Vdc	18	17	16	15	14	13	12	11	10	9	8	7	6

Use for systems with DC/DC converters. The value calculated below must be less than DC/DC converter max DC input voltage (STEP 6)

B. Module V_{oc} (STEP S2) = _____ x # of modules per converter (STEP S6) _____ x C_f (STEP 1) _____ = _
_____ V

Table S2. Largest Module V_{oc} for Single-Module DC/DC Converter Configurations (With 80V AFCI Cap) (CEC 690.7 and 690.11)

S8) Maximum System DC Voltage from DC/DC Converters to Inverter — Only required if Yes in Step S6
Maximum System DC Voltage = ____ Volts

S9) Sizing Source Circuit Conductors

Source Circuit Conductor Size = Min. #10 AWG copper conductor, 90° C wet (USE-2, PV Wire, XHHW-2, THWN-2, RHW-2)

For up to 8 conductors in roof-mounted conduit exposed to sunlight at least ½” from the roof covering. (CEC 310)

Note: For over 8 conductors in the conduit or mounting height of lower than ½” from the roof, this plan is not applicable.

S10) Are PV source circuits combined prior to the inverter? Yes No

If No, use Single Line Diagram 1 with Single Line Diagram 3 and proceed to Step S12.

If Yes, use Single Line Diagram 2 with Single Line Diagram 4 and proceed to Step S11 after this step.

Is source circuit OCPD required? Yes No

Source circuit OCPD size (if needed): 15 Amps

Are the source circuits combined on the roof? Yes No

If “Yes,” the DC output of the combiner shall have a load breaker disconnecting means located in the combiner or within 1.8m (6ft) of the combiner.

S11) Sizing PV Output Circuit Conductors — If strings are combined (answered “Yes” in Step S10), Output Circuit Conductor Size = Min. #6 AWG copper conductor.



SOLAR PV STANDARD ELECTRICAL PLAN: CENTRAL/STRING INVERTER SYSTEMS

S11) Sizing PV Output Circuit Conductors — If strings are combined (answered “Yes” in Step S10), Output Circuit Conductor Size = Min. #6 AWG copper conductor.

S12) Inverter Disconnect

Does the inverter have an integrated DC disconnect? Yes No If Yes, proceed to Step S13.
If no, the external DC disconnect to be installed is rated for ___Amps (DC) and ___Volts (DC)

S13) Inverter Information

Manufacturer: _____ Model: _____

Max Continuous AC Output Rating: ___Amps

Integrated DC Arc-Fault Circuit Protection? Yes No (If No is selected, this plan is not applicable.)

Grounded or Ungrounded System? Grounded Ungrounded

AC Information:

S14) Sizing Inverter Output Circuit Conductors and OCPD

Inverter Output OCPD rating = ___Amps (Table 3)

Inverter Output Circuit Conductor Size = ___AWG (Table 3)

Table 3. Minimum Inverter Output OCPD and Circuit Conductor Size									
Inverter Continuous Output Current Rating (Amps) (Step 14)	12	16	20	24	28	32	36	40	48
Minimum OCPD Size (Amps)	15	20	25	30	35	40	45	50	60
Minimum Conductor Size (AWG, 75°C, Copper)	14	12	10	10	8	8	6	6	6



WEST HOLLYWOOD
8300 Santa Monica Boulevard West Hollywood, CA 90069-6216

Building & Safety Division
tel 323.848.6475 fax 323.848.6569

SOLAR PV STANDARD ELECTRICAL PLAN: CENTRAL/STRING INVERTER SYSTEMS

Load Center Calculations (Omit if a load center will not be installed for PV OCPDs)

S18) Load Center Output:

Calculate the sum of the maximum AC outputs from each inverter.

Inverter #1 Max Continuous AC Output Current Rating [STEP S13] _____ × 1.25 = _____ Amps

Inverter #2 Max Continuous AC Output Current Rating [STEP S13] _____ × 1.25 = _____ Amps

Total inverter currents connected to load center (sum of above) = _____ Amps

Conductor Size: _____ AWG

Overcurrent Protection Device: _____ Amps

Load center busbar rating: _____ Amps

Can the load center accept more than two breakers? Yes No

If Yes, the sum of 125% of the inverter output circuit currents and the rating of the overcurrent device protecting the busbar shall not exceed 120% of the ampacity of the busbar.

If No, the sum of ampere rating of the two PV overcurrent devices shall not exceed the rating of the busbar.



SINGLE-LINE DIAGRAM #3 – ADDITIONAL INVERTER FOR DIAGRAM #1

INVERTER # 2

CHECK A BOX FOR WHETHER SYSTEM IS GROUNDED OR UNGROUNDED: GROUNDED (INCLUDE GEC) UNGROUNDED

REFER TO STEP 16 FOR RAPID SHUTDOWN DETAILS FOR UNGROUNDED SYSTEMS:

-DC OCPD MUST DISCONNECT BOTH CONDUCTORS OF EACH SOURCE CIRCUIT

- UNGROUNDED CONDUCTORS MUST BE IDENTIFIED PER 210.5(C). WHITE-FINISHED CONDUCTORS ARE NOT PERMITTED.

IF DC/DC CONVERTERS ARE USED, CHECK THE BOX BELOW THE CORRESPONDING CONFIGURATION

PARALLEL DC/DC CONVERTERS ON ONE SOURCE CIRCUIT (FIXED UNIT VOLTAGE DC/DC CONVERTERS)

DC/DC CONVERTERS ARE ALL RUN IN SERIES (FIXED SOURCE CIRCUIT VOLTAGE DC/DC CONVERTERS)

ENTER "N/A" WHERE SUITABLE FOR WHEN NOT USING CONDUIT OR CABLE AS PERMITTED BY CODE

CONDUCTOR/CONDUIT SCHEDULE					
TAG	DESCRIPTION AND CONDUCTOR TYPE	CONDUCTOR SIZE	NUMBER OF CONDUCTORS	CONDUIT/CABLE TYPE	CONDUIT SIZE
A	USE-2 <input type="checkbox"/> OR PV-WLRE <input type="checkbox"/>				
B	EGG/GEC:				
C	EGG/GEC:				

Δ TAG	DESCRIPTION
1	SOLAR PV MODULE / STRING
2	DC/DC CONVERTERS INSTALLED? YES / NO (IF YES, STEPS 6 & 8 REQUIRED)
3	SOURCE CIRCUIT JUNCTION BOX INSTALLED? YES / NO
4	SEPARATE DC DISCONNECT INSTALLED? YES / NO
5	INTERNAL INVERTER DC DISCONNECT? YES / NO
6	CENTRAL INVERTER
7	*SEPARATE AC DISCONNECT INSTALLED? YES / NO
8	TO LOAD CENTER ON LINE DIAGRAM 1

* Consult with your local AHJ and /or Utility

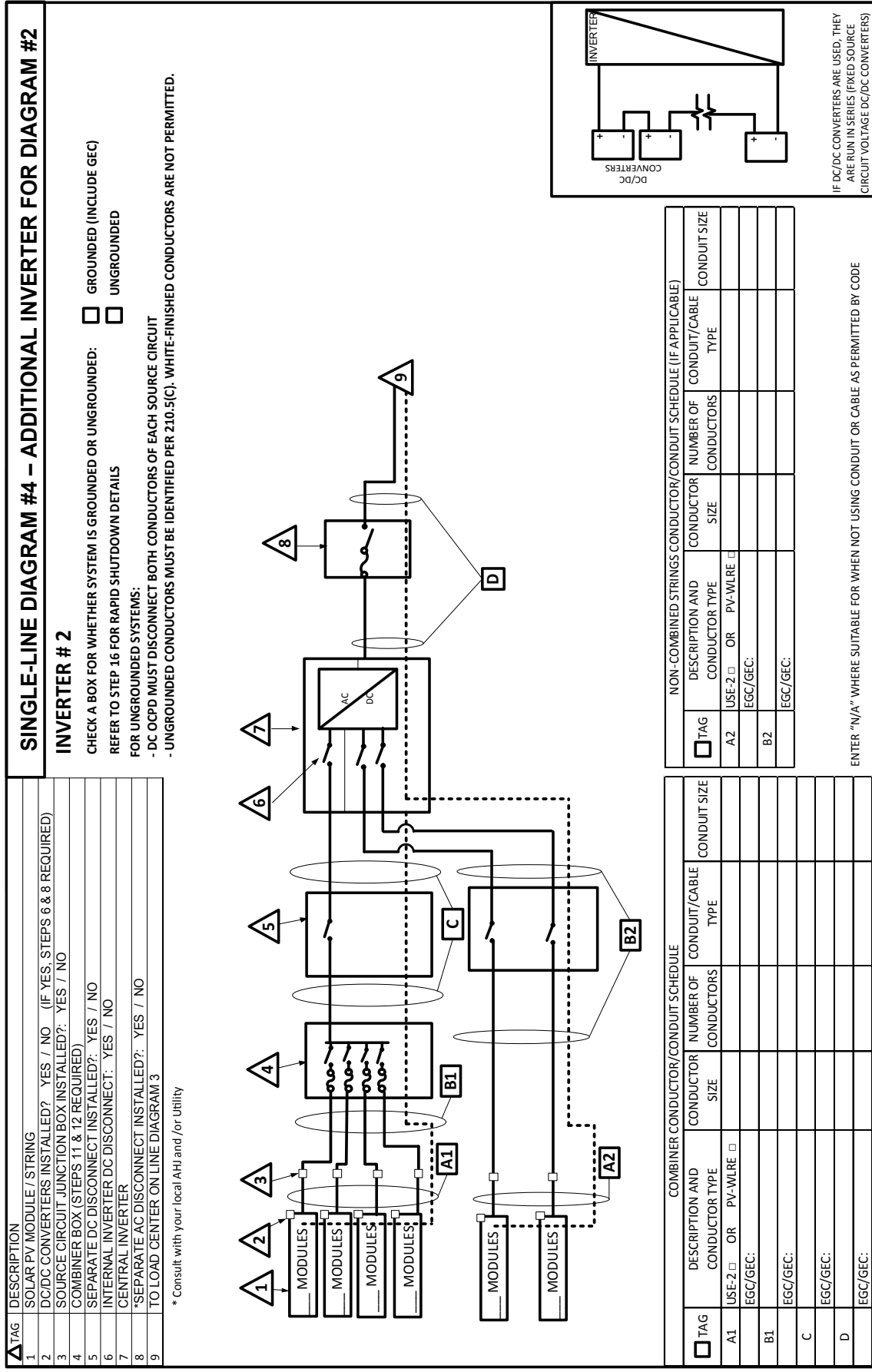

SOLAR PV STANDARD PLAN

Roof Layout Diagram for One- and Two-Family Dwellings

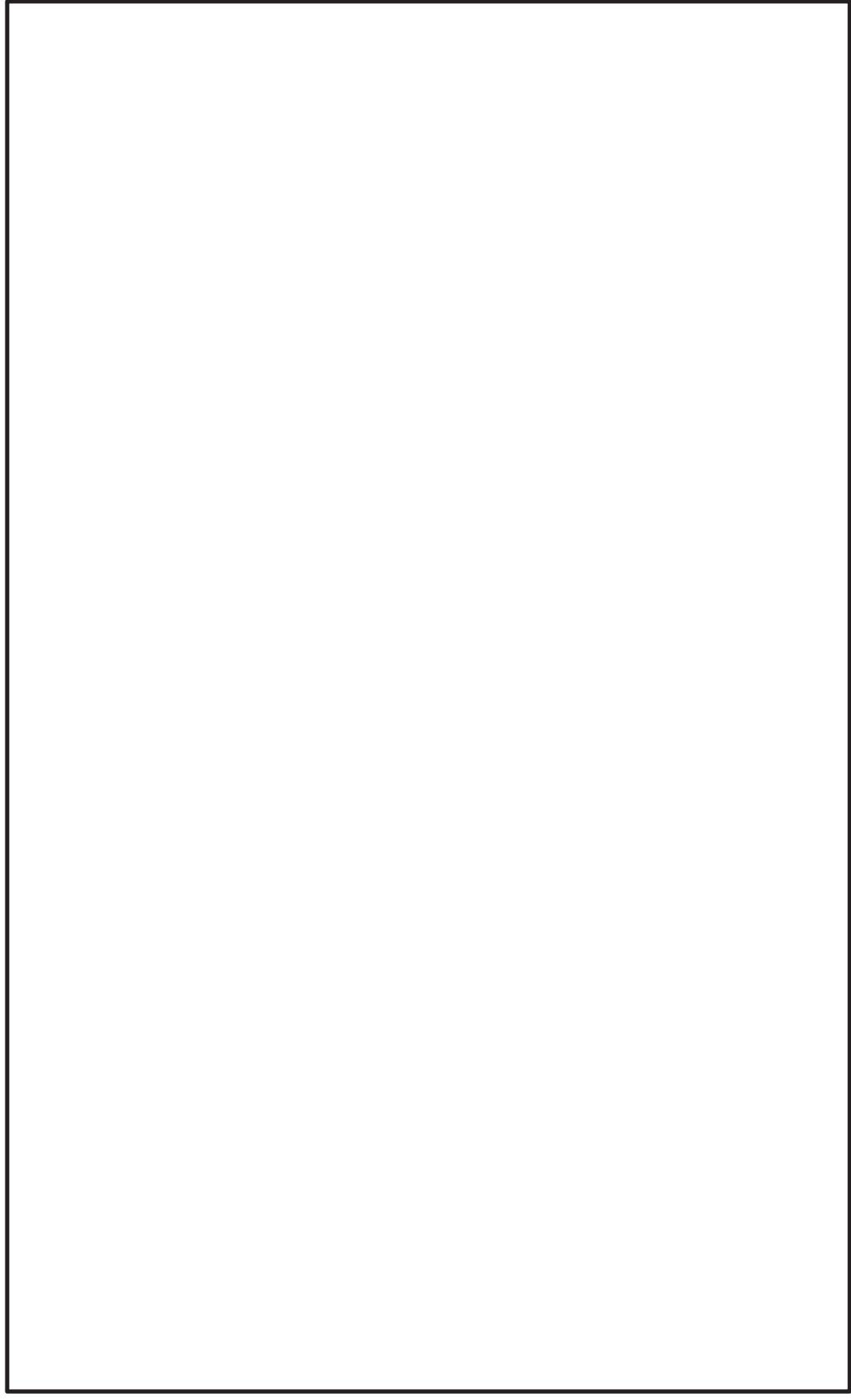

Items required: roof layout of all panels, modules, clear access pathways and approximate locations of electrical disconnecting means, roof access points, and rapid shutdown initiation device.